

FRYER

MACHINE SYSTEMS

Precision Built Solutions



DESIGNED, ENGINEERED
& ASSEMBLED IN USA

2022 CATALOG

Why Fryer

Welcome to Fryer and our Precision Built Solutions. From our first toolroom bed mill in 1995 to our newest 5 axis mills, Fryer has created the unique solutions to your machining needs. Our toolroom technology makes all of our machines easier to set-up, program and operate. As a result you can make a single part in half the time of a manual or CNC machine. Our USA made quality and precision defines our machine tools and our custom configurations allow you features not available from ANY other builder. At Fryer we feature unique high quality machines with more features and more flexibility.



OUR COMPANY

- Over 30 years experience
- Family owned & operated
- Over 6,000 machines in use

OUR FACTORY

- Modern 50,000 sq. ft. manufacturing facility
- Hand built assembly system
- Sophisticated quality control



CUSTOMER SUPPORT

- Remote diagnostics and tele-service
- Fully stocked parts department with same day shipping
- No charge phone service

OUR PEOPLE

- Local New England craftsmen
- Made in the USA
- Excellent engineering & application support
- People who care



Table of Contents

Toolroom Mills	
■ MB-Q Series	4
■ MB-R Series	6
■ CM Series	8
Toolroom Lathes	
■ ET-TR Series	10
■ ET-LC Series	12
■ ET-XL Series	13
Vertical Machines	
■ MC-B Series	14
■ MC-L Series	15
■ VB Series	16
5 Axis Machining Centers	
■ 5X Series	18
■ TR Series	19
■ SX Series	20
Traveling Column Machines	
■ TC-H Series	22
■ TC-V Series	23
Horizontal Machines	
■ HR Series	24
■ HB Series	26
Turning Centers	
■ VT Series	28
■ SL Series	30
High Precision Rotary Tables	
32	
Control	
■ Fryer / Siemens 828-HS	34
■ Fryer / Siemens Touch 2300	36
■ Fryer / Fanuc 31i B5	37
■ Fryer / Fanuc 0i Plus	38
Specifications	
39	

Machines may be shown with optional features

MB-Q Series - Toolroom Bed Mill with Manual Quill Head

High Quality Toolroom Mills for Small Batch Production

MB-10Q 32" x 17" x 19"

MB-14Q 40" x 20" x 20"

MB-16Q 60" x 25" x 24"

All models feature 6" manual quill

- **Manual, Semi-CNC or Full-CNC Modes**
- **Extremely Easy to Use**
- **Fast Set Up for One Off-Parts**
- **Perfect for Repair Tool & Die, Maintenance & Job Shop**



OVERVIEW

The Fryer MB-Q Series is the ultimate mill for toolroom applications. Designed and built to be the finest toolroom mill available, these machines are easier to use, more accurate and last longer than any other toolroom mill. Equipped with a manual quill and manual handwheels, the "Q" Series gives you the flexibility to use in manual, semi-CNC or full-CNC modes. The conversational control makes programming easy so even one-off parts can be done quickly and efficiently.

EASE OF USE

- Manual handles for X and Y axis
- Manual quill with optional glass scale
- "Do One" cycles for pockets, drilling, bolt circles & more
- Simple menu programming – no codes of any kind
- Reads standard G & M codes from CAD-CAM systems
- Solid model part verification

FEATURES

- Versatile quill head with gear box
- One-touch set-up buttons
- Rigid tapping with peck feature
- Handwheel run makes testing programs safer
- 10 HP 4,500 RPM CAT-40 taper spindle
- Standard 2 year warranty

	MB-10Q	MB-14Q	MB-16Q
X Travel	32"	40"	60"
Y Travel	17"	20"	25"
Z Travel	19"	20"	24"
Tool Type/Taper	CAT 40 (NST 40 or BT 40 optional)		
Spindle Speed	Low 10-500 High 100-4,500		
ATC Tool Cap	N/A		
Rapid Traverse	400 IPM		
Machine Weight	5,000 lbs.	6,000 lbs.	8,800 lbs.

For more information on the MB-Q Series, please visit http://www.fryermachine.com/products/toolroom_mills/mb_q_series.php



MB-Q QUILL HEAD

The versatile Quill head features a 40 taper quill type spindle with 6" of manual movement. The head can be rotated right to left up to 90 degrees and includes a 2 speed gearbox with 4,500 RPM max speed.



MANUAL OPERATION

- Manual handles for X and Y axis
- Digital readout for positioning
- Manual quill with optional glass scale

SEMI-CNC OPERATION

- Power-feed function
- Simple "Go To" function for axis positioning
- "Do One" function allows you to easily cut pockets, chamfers, radius, boring and more

FULL CNC OPERATION

- Simple menu system – no codes of any kind
- Reads standard G & M codes from CAD-CAM systems
- High speed machining function for mold makers
- Full 3 axis contouring control
- Solid model part verification

MB-R Series - Toolroom Bed Mill with Rigid Spindle Head

High Quality Toolroom Mills for Small Lot Production

MB-10R 32" x 17" x 19"

MB-14R 40" x 20" x 20"

MB-16R 60" x 25" x 24"

- **Rigid Spindle & Optional Tool Changer**
- **Compact size**
- **Fast Set-Up and Programming**
- **Perfect for Both Single or Multi Part Production**



MB-14R

FEATURES

- 12 HP 8,000 RPM CAT-40 taper spindle
- 12 or 20 tool automatic tool changer
- Rigid tapping with peck feature
- Rugged heavy duty Meehanite castings
- Absolute encoders - no homing required
- Standard 2 year warranty

OVERVIEW

The Fryer MB-R Series is the perfect mill for job shop and toolroom applications. Built to be the most accurate and reliable machine of its type, it is also extremely easy to use. Equipped with a rigid spindle and optional tool changer, this machine is capable of single or multi part production. The conversational control makes programming easy so even one off parts can be done quickly and efficiently.

EASE OF USE

- Fast set-up keys
- Electronic handles for manual movement
- "Do One" semi-automatic mode
- Simple menu programming – no codes of any kind
- Reads standard G & M codes from CAD-CAM systems

TECHNOLOGY

- All digital drives and motors
- Regenerative drives save 40% energy use
- All axes laser calibrated & ballbar verified
- 400 IPM rapid feedrate
- Automatic drawbar
- Automatic tool setter
- One touch set-up buttons
- 4th axis capability
- Automatic part probe
- Solid model part verification

For more information on the MB-R Series, please visit http://www.fryermachine.com/products/toolroom_mills/mb_r_series.php



MB-R RIGID HEAD

Features a high speed 8,000 RPM 40 taper spindle. Rigid style head allows the use of an automatic tool changer.



MB-10R

3 HANDWHEEL OPTION

- 3 handwheels for manual control
- Joystick feed control for X and Y
- Coarse / fine feed switch
- Electronic stops for controlling positioning
- Cut angles by turning one handwheel
- Do One cycles for pocketing and drilling



TABLE MOUNTED SPLASH GUARD

Table mounted guard helps to contain coolant and chips. It features two siding doors with a door safety switch that meets safety requirements for many companies.

	MB-10 R	MB-14 R	MB-16 R
X Travel	32"	40"	60"
Y Travel	17"	20"	25"
Z Travel	19"	20"	24"
Tool Type/Taper	CAT - 40 (BT-40 optional)		
Spindle Speed	60 - 8,000 RPM		
ATC Tool Capacity	12 (20 optional)		
Rapid Traverse	400 IPM		
Machine Weight	5,000 lbs.	7,000 lbs.	10,000 lbs.

CM Series - Precision Compact Mill

Best Made Compact Toolroom Mills

CM-15 15" x 10" x 15"

CM-20 20" x 13" x 20"

- **Simple Conversational Programming**
- **Flexibility - Easy to Set Up & Move**
- **Ultra Accurate**
- **Perfect for Toolroom, Job Shop & Secondary Operations**



CM-15

OVERVIEW

The Fryer CM Series is the perfect tool for toolroom, job shop and secondary operations. Built on a solid cast iron platform and using high precision ballscrews, spindle and ATC, the CM can hold the demanding tolerances that industry requires. Programming is accomplished with industry standard G code or Siemens advanced 'Shop Mill' programming. Equipped with an impressive list of standard features the CM Series is by far the best compact milling machine available today.

FEATURES

- Automatic Tool Changer
- 40 Taper Spindle – 8,000 RPM
- 7.5 HP spindle motor
- Move easily to where a spindle is needed
- Park next to larger machine as 2nd Op
- Fast set-up buttons

QUALITY

- Rugged Construction
- Precision ground ballscrews
- Super accurate
- Rigid tapping with peck feature
- Simple menu programming - No codes of any kind
- G code editor runs Fanuc G code

For more information on the CM Series, please visit http://www.fryermachine.com/products/toolroom_mills/cm_series.php

SPINDLE FEATURES

- 8,000 RPM 40 taper
- 10,000, 12,000 or 15,000 inline option
- 21,000, 30,000 electric option
- Built-in coolant nozzles
- 7.5 HP or 15 HP spindle motors



PORTABLE

- Move easily to where a spindle is needed
- Park next to larger machine as 2nd Op
- Easy to level and set-up

	CM-15	CM-20
X Travel	15"	20"
Y Travel	10"	13"
Z Travel	15"	20"
Tool Type/Taper	CAT 40 (BT optional)	
Spindle Speed	60 - 8,000 RPM (10K, 12K, 15K, 21K, 30K optional)	
ATC Tool Cap	8 Station	10 Station (20 optional)
Rapid Traverse	500 IPM (1,200 optional)	
Machine Weight	2,350 lbs.	4,300 lbs.



CM-20

ET - TR Series - Easy Turn - Toolroom Turning

Simplified Small Batch Turning

ET-16 16" Swing

ET-18 18" Swing

ET-21 21" Swing

ET-25 25" Swing

Center Distances 40", 60", 80", 120"

Spindle Bore Sizes 2.0", 3.4", 4.1"

- **Manual, Semi-CNC or Full-CNC Modes**
- **Easier to Use Than Conventional Lathe**
- **Handle Driven "Do One" Cycles Eliminates Manual Set-Ups**
- **Perfect for Prototype, Repair, Job Shop & Toolroom**



ET-18

OVERVIEW

Designed by toolmakers for toolmakers, the Fryer Easy Turn Series provides rugged construction and high accuracy in a compact toolroom lathe. The Easy Turn is easier to use than a conventional lathe yet offers the productivity of a CNC. Time consuming manual set-ups for threading, chamfers, and contours are eliminated by the Easy Turn's handle driven "Do One" cycles and electronic stops. Multi-mode operations allow manual use, semi-auto use and full CNC operation. This flexibility is perfect for repair shops, tool and die, prototype and job shops alike.

QUALITY

- High quality thermally stable Meehanite castings
- Hardened and ground ways with Turcite B liners
- Two speed auto-shift gear box
- C3 grade double nut ball screws with class 7 bearings
- Hand built precision +/- .0002"
- 2 Year warranty

EASE OF USE

- Manual mode with dual handles
- "Do One" semi-automatic mode
- Simple menu programming mode
- 3D graphic verification
- Standard G code programming
- Handwheel run mode



ET-21

MANUAL OPERATION

- Manual handles for X and Z axis
- Electronic stops make manual positioning easy
- Create chamfers & taper cuts by turning one handle

SEMI-CNC OPERATION

- Programmable power-feed function
- Simple "Go To" function for axis positioning
- "Do One" function allows you to easily cut threads, thread repair, chamfers, boring, drilling, & more

FULL CNC OPERATION

- Simple menu system – no codes of any kind
- Reads standard G & M codes from CAD/CAM systems
- Geometry Creator calculates missing dimensions
- 3D part verification – solid model or wire frame
- Safe & fast Handwheel Run mode

	ET-16	ET-18	ET-21	ET-25
Swing Over Bed	16"	18"	21"	25"
Swing Over Cross Slide	8.125"	9.125"	12"	16"
Distance Between Centers	40"	40"	60"	60"
Optional Dist b/Centers	60"	60"	40", 80", 120"	40", 80", 120"
Spindle Nose	Camlock D1-6		Camlock D1-8	
Spindle Bore	2.05"	2.05" (3.4")	3.40" (4.01")	
Spindle Motor HP (Peak)	10 HP		15 HP	
Spindle Speed (RPM)	100 - 3,000	50 - 2,500	50 - 2,000	50 - 2,000

ET - LC Series - Easy Turn - Large Capacity Turning

Large Capacity Small Batch Turning

ET-30 30" Swing

ET-40 40" Swing

Center Distances 60", 80", 120", 160", 200"

Spindle Bore Sizes 4.1", 6.1", 9", 12"

- **Easy-to-use Operator Interface**
- **High Performance Drives & Motors**
- **Simple Programming for One-Off Parts**
- **Perfect for Large Parts**

QUALITY

- Precision built four-speed geared headstock
- Digital servo motors & drives
- Manual tailstock with large #6 center
- Heavy duty double V-way construction
- Best in class construction
- 30 HP high torque spindle motor

FEATURES

- Full manual mode with 2 handwheels
- One button fast setup simplifies process
- Fast menu programming system
- Standard G and M code programming
- Thread repair cycle
- 3D graphics for part verification

OVERVIEW

Heavy duty construction distinguishes the Fryer ET Large Capacity Series lathes. Designed for applications where high rigidity is required, these machines can be custom configured for your most demanding applications. Easy-to-use operator interface allows simple shop floor programming for one-off parts. High performance drives and motors combine with standard G-Code interface allowing production to run smoothly and efficiently.

	ET-30	ET-40
Swing Over Bed	30"	40"
Swing Over Cross Slide	18"	28"
Distance b/Centers	60"	60"
Optional Dist b/Centers	80", 120", 160", 200"	
Spindle Nose	Camlock D1-11 (A2-11, A2-15)	
Spindle Bore	4.10" (6.1", 9.0", 12.0")	
Spindle Motor HP (Peak)	30 HP (50 HP)	
Spindle Speed (RPM)	10 - 1,500 (1,000, 750)	



ET-30

For more information on the ET-LC Series, please visit http://www.fryermachine.com/products/toolroom_lathes/etlc_series.php

ET - XL Series - Easy Turn - Extra Large Capacity Turning

Extra Large Capacity Small Batch Turning

- Easy-to-use Operator Interface
- Fast Set-Up Buttons
- Heavy Duty Construction
- Perfect for Extra Large Part Machining

ET-50	50" Swing	Center Distances
ET-65	65" Swing	60", 80", 120", 160", 200", 240", 280", 340"
ET-80	80" Swing	Spindle Bore Sizes
		6.1", 9", 10", 12", 16", 20"



ET-50

OVERVIEW

Fryer Machine's ET-XL Series Lathes provide the ultimate in performance for your large part machining needs. These wide bed (30") heavy duty engine lathes provide incredible capacity to handle the toughest jobs you have. Designed as the heaviest machines in its class, these machines feature centers distances up to 340" and spindle bores up to 20". Innovative features like live tooling, C axis, Y axis, automatic chucks and auto steady rests allow you to customize the machine to best suit your application.

QUALITY

- Heavy duty 50 HP high torque spindle
- Hydraulic tailstock with built-in live center
- Digital servo motors and drives with absolute encoders

FEATURES

- 30" wide bed with center mounted ballscrew
- Standard 6.1" spindle bore
- Three speed autoshift geared headstock
- Full manual mode
- Shop floor programming system
- One button fast setup - simplifies setup process

	ET-50	ET-65	ET-80
Swing Over Bed	50"	65"	80"
Swing Over Cross Slide	35"	50"	65"
Distance b/Centers	60"	60"	60"
Optional Dist b/Centers	80", 120", 160", 200", 240", 280", 340"		
Spindle Nose	A2-11 (A2-15, A2-20, A2-28)		
Spindle Bore	6.1" (9", 10", 12", 16", 20")		
Spindle Motor HP (Peak)	50 HP		
Spindle Speed (RPM)	3 - 750 (600, 375, 300)		

For more information on the ET-XL Series, please visit http://www.fryermachine.com/products/toolroom_lathes/etxl_series.php

MC-B Series - Box Way Performance Machining Centers

Heavyweight Machining Centers

MC-30B	30" x 18" x 22"
MC-40B	40" x 20" x 28"
MC-45B	45" x 25" x 25"
MC-60B	60" x 30" (35") x 28" (38")
MC-80B	80" x 35" (40") x 30" (34")
MC-100B	100" x 35" (40") x 30" (34")

OVERVIEW

Fryer's MC-B Series offers the ultimate in performance by featuring heavyweight castings with box way construction. The standard 24 tool arm type ATC and 1,200 IPM rapids produce more parts per hour. Fully digital control and drives combined with fast set-up and programming maximize performance and reliability.



MC-60B

- **Box way rigidity**
- **24 tool ATC**
- **40 or 50 taper**
- **1,200 rapids**

FEATURES

- Heavy duty box ways
- Fast 1,200 IPM rapids
- 24 tool arm type ATC
- High torque 30 HP motor
- 40 or 50 taper spindles
- Compact size

PRODUCTIVITY

- Fast conversational programming
- Fast set-up keys
- Absolute encoders
- Regenerative drive technology
- Chip management system
- Coolant thru spindle

	MC-30B	MC-40B	MC-45B	MC-60B	MC-80B	MC-100B
X Travel	30"	40"	45"	60"	80"	100"
Y Travel	18"	20"	25"	30" (35")	35" (40")	35" (40")
Z Travel	22"	28"	25"	28" (38")	30" (34")	30" (34")
Tool Type/Taper	CAT 40 (CAT 50 option; BT option)					
Spindle Speed	60 - 8,500 RPM (10K, 12K, 15K, 21K, 30K Optional)					
ATC Tool Cap	24 Station Arm Type (40 Tool)					
Rapid Traverse	1,200 X,Y - 900 Z		600 X,Y,Z 400 X,Y,Z			
Machine Weight	9,900 lbs.	12,100 lbs.	14,500 lbs.	20,000 lbs.	23,000 lbs.	26,000 lbs.

For more information on the MC-B Series, visit http://www.fryermachine.com/products/vertical_machining_centers/mc-b_series.php

MC-L Series - Linear Way High Speed Machining Centers

High Speed Machining Centers



MC-40L

- MC-24L** 24" x 16" x 17"
- MC-30L** 30" x 20" x 20"
- MC-40L** 40" x 22" x 22"
- MC-45L** 45" x 25" x 25"
- MC-60L** 60" x 30" (35") x 28" (38")

- Roller type linear ways
- 30 tool ATC
- 40 taper Big Plus – 10,000 RPM
- Fast 1,450 rapids

OVERVIEW

The Fryer MC-L series features high speed and high performance. Standard features include high speed 30 tool ATC, a 10,000 RPM inline spindle, a high torque 30 HP motor and a super fast 1,450 IPM rapid feedrate. Combined with roller type linear ways and heavy duty FEA designed castings, the MC-L series is the ultimate compact VMC.

	MC-24L	MC-30L	MC-40L	MC-45L	MC-60L
X Travel	24"	30"	40"	45"	60"
Y Travel	16"	20"	22"	25"	30" (35")
Z Travel	17"	20"	22"	25"	28" (38")
Tool Type/Taper	Big Plus CAT 40 (BT option)				
Spindle Speed	60 - 10,000 RPM (12K, 15K, 21K, 30K Optional)				
ATC Tool Cap	30 Station High Speed Arm Type (40 Option)				
Rapid Traverse	1,450 X,Y, Z	1,450 X,Y, Z	1,450 X,Y, Z	1,200 X,Y, Z	1,200 X,Y, Z
Machine Weight	7,900 lbs.	8,400 lbs.	9,500 lbs.	14,500 lbs.	20,000 lbs.

QUALITY

- Roller type linear ways
- Fast 1,450 IPM rapids
- 30 tool arm type ATC
- High torque 30 HP motor
- 40 taper Big Plus – 10,000 RPM
- Compact size

PRODUCTIVITY

- Fast conversational programming
- Fast set-up keys
- Absolute encoders
- Regenerative drive technology
- Chip management system
- Coolant thru spindle

For more information on the MC-L Series, visit http://www.fryermachine.com/products/vertical_machining_centers/mc-l_series.php

VB Series - Extra Large Machining Centers

Large Frame Machining Centers

- VB-60** 60" x 30" x 28"
- VB-80** 80" x 35" (40") x 26" (34")
- VB-100** 100" x 35" (40") x 26" (34")
- VB-120** 120" x 40" (50") x 40"
- VB-160** 160" x 40" (50") x 40"

- **X travel to 160"**
- **Simple Set-Up & Programming**
- **Easy Loading of Large Parts**
- **Excellent value**

OVERVIEW

Designed as a high performance machining center without an enclosure, the Fryer VB Series offers versatility and value. Ideal for production and job shop applications, the VB open design and rugged construction allows for easy loading of large parts. Extremely simple set-up and programming make this machine highly efficient for even short run parts. The VB series is also equipped with an impressive set of standard features unmatched by any machine in its class.



VB-160



VB-100

FEATURES

- Box way construction with Turcite B liners
- Extra large travel up to 160" x 50"
- Rugged 40 and 50 taper spindle
- Automatic tool changer
- Rigid tapping with peck feature
- High volume flood coolant system

- C3 grade double-nut ball screws with Class 7 bearings
- Massive 6" 8,000 RPM spindle cartridge
- All axes laser calibrated & ballbar verified
- Hand built precision +/- .0002" entire travel
- X travel 60" to 160"
- Simple conversational or G code programming
- High speed all digital control system
- Absolute encoders - no homing required
- Siemens or Fanuc CNC

PRODUCTIVITY

- Fast conversational programming
- Fast set-up keys
- Absolute encoders
- Regenerative drive technology
- Available full guarding
- Coolant thru spindle

	VB-60	VB-80	VB-100	VB-120	VB-160
X Travel	60"	80"	100"	120"	160"
Y Travel	30"	30" (40")	35" (40")	40" (50")	40" (50")
Z Travel	28"	26" (34")	26" (34")	40"	40"
Tool Type/Taper	CAT 40 or BT-40 (Optional 50 Taper)				
Spindle Speed	60 - 8,000 RPM (10K,12K,15K Refrigerated Optional)				
ATC Tool Cap	20 Carousel (24, 40, 60 Arm Type Optional)				
Rapid Traverse	1,000 X, Y 700 Z	600	400	400	400
Machine Weight	15,000 lbs.	18,500 lbs.	20,500 lbs.	32,000 lbs.	37,000 lbs.

5X Series - 5 Axis Simultaneous with Articulating Spindle

5-Axis with Rotating Spindle

- 5X-60** 60" x 30" x 35"
- 5X-100** 100" x 35" x 34"
- 5X-120** 120" x 50" x 40"
- 5X-160** 160" x 50" x 40"

OVERVIEW

The Fryer 5X Series features the Kessler tilting/rotary head which provides 360° of rotation and 200° of spindle tilt. This flexible spindle solution is perfect for the aerospace, automotive and oil field industries where rotating the part is not practical. Available in travel sizes of 60" to 160" and featuring full 5 axis Siemens 840D or Fanuc 31i B5 CNC controls.

PRODUCTIVITY

- 2 axis spindle flexibility
- Perfect for large parts
- Fast set-up cycles
- Compact size
- Siemens 840D SL CNC
- Fanuc 31i B5 CNC

- **360° of rotation and 200° of spindle tilt**
- **Designed for cutting steel & tough alloys**
- **High power torque motors & Heidenhain glass scales**
- **Perfect for aerospace, automotive & energy industries**

FEATURES

- German-made Kessler 2-axis head
- 360° rotation, 200° tilt
- 40 tool high speed, twin arm ATC
- Excellent accessibility for crane loading
- 5 arc second rotary accuracy
- High torque 55 HP, 15,000 HP spindle



5X-60

	5X-60	5X-100	5X-120	5X-160
X Travel	60"	100"	120"	160"
Y Travel	30"	35"	50"	50"
Z Travel	35"	34"	40"	40"
Tool Type/Taper	HSK-63A			
Spindle Speed	200 - 18,000 RPM		200 - 15,000 RPM	
ATC Tool Cap	40 Station Arm Type (60 tool optional)			
Rapid Traverse	1,200 IPM	800 IPM	400 IPM	400 IPM
Machine Weight	20,000 lbs.	25,500 lbs.	34,000 lbs.	37,000 lbs.

For more information on the 5X Series, please visit http://www.fryermachine.com/products/5_axis_machining_centers/5x_series.php

TR Series - 5 Axis Simultaneous with Trunnion Table

5-Axis with Trunnion Table

- 2 Axis tilting trunnion table
- 360° of rotation and 110° of table tilt
- Designed for cutting steel & tough alloys
- Perfect for job shops and multi-sided machining

TR-200 14" x 14" x 20"

TR-320 30" x 16" x 20"

TR-600 45" x 25" x 25"

Max Workpiece Diameters 10.5", 23.62", 32.67"

Platter Sizes 8", 12", 24"

OVERVIEW

The Fryer TR Series 5-Axis Machining Centers feature a Trunnion Table that rotates 360° and tilts 110°. The machine features a 24 tool ATC, 12,000 RPM spindle, 30 HP and 1,200 IPM rapids. The standard Siemens 2300 CNC features the ultimate in 5-axis features and programming convenience.

FEATURES

- Fryer made 2-Axis trunnion table
- 360° rotation, 110° tilt
- 24 tool high speed, twin arm ATC
- Excellent accessibility for crane loading
- 15 arc second rotary accuracy
- High torque 30 HP, 12,000 HP spindle



TR-600

PRODUCTIVITY

- 2 axis trunnion flexibility
- Perfect for multi-side production
- Fast set-up cycles
- Compact size
- Siemens 840D SL CNC
- Fanuc 31i B5 CNC

	TR-170	TR-320	TR-600
X Travel	20"	30"	45"
Y Travel	13"	16"	25"
Z Travel	20"	20"	25"
Platter	8"	12"	24"
Spindle	40 Taper 12,000 RPM		
ATC Tool Cap	24 Tool Arm Type		
Rapid Traverse	1,200 IPM		
Machine Weight	5,600 lbs.	9,200 lbs.	17,500 lbs.

For more information on the TR Series, please visit http://www.fryermachine.com/products/5_axis_machining_centers/tr_series.php

SX Series - 5 Axis Simultaneous with Tilting Spindle

5-Axis with Tilting Spindle

OVERVIEW

SX-45	45" x 25" x 25"
SX-60	60" x 30" x 35"
SX-80	80" x 35" x 34"

The Fryer SX Series 5 Axis Machining Centers feature a swivel head that moves +/- 110°. The machine has a 40 tool ATC, 18,000 RPM spindle, 40 HP and 1,200 IPM rapids. It is available with a flush mounted 24" rotary table or a table mounted 12" rotary table. Full 5 axis contouring with either the Siemens 840D CNC or the Fanuc 31i B5 CNC.

- +/- 110° tilt head
- Flush or table mounted rotary table
- High torque, high speed spindle
- High rigidity for heavy cutting

	SX-45	SX-60	SX-80
X Travel	45"	60"	80"
Y Travel	25"	30"	35"
Z Travel	25"	35"	34"
Tool Type/Taper	BIG PLUS CAT-40 (BT-40, HSK-63)		
Spindle Speed	100 - 18,000 RPM		
ATC Tool Cap	40 Station Arm Type		
Axis Rapid Traverse	1,200 IPM X, Y 1,000 IPM Z		
Machine Weight	17,500 lbs.	21,500 lbs.	25,000 lbs.



SX-60

PRODUCTIVITY

- Use as 3 or 5 axis
- Fast set-up cycles
- Conversational or G code programming
- Perfect for multi-sided work
- Siemens 840D SL 5 axis CNC
- Fanuc 31i B5 5 axis CNC



HIGH PERFORMANCE SPINDLE

Features high performance motorized spindle. 18,000 RPM, Big Plus CAT-40, 40 HP with 85 ft/lbs. of torque.

FEATURES

- 18,000 RPM high torque 40 HP motorized spindle
- +/- 110° tilt rotation
- Roller Cam zero backlash rotary head
- CAT-40 Big Plus dual contact taper
- 40 tool high speed twin arm ATC
- Fast 1,200 IPM rapids



BUILT IN 4TH AXIS ROTARY TABLE

Flush mounted 4th axis table, platter available in 24" diameter. Full interpolated contouring and positioning with 12 arc/sec accuracy. Includes rotary table controller and hydraulic brake.

TC-H Series - Horizontal Traveling Column

Traveling Column Horizontal Machining Center

TC-40H	40" x 29" x 26"
TC-80H	80" x 24" x 24" (32")
TC-120H	120" x 24" x 24" (32")
TC-160H	160" x 24" x 24" (32")
TC-240H	240" x 24" x 24" (32")
TC-320H	320" x 24" x 24" (32")

OVERVIEW

The Fryer TC-H Series features a fixed table and traveling column design. It is equipped with a rugged 40 taper horizontal spindle featuring a high torque 30 HP spindle motor with 155 ft/lbs of torque. The fixed table allows table loads of more than 10,000 lbs. while offering versatility in part fixturing. Available in sizes ranging from 40" X travel all the way to a huge 320" travel machine.

- Fixed table features high load capacity
- Large X axis travel to 320"
- Z axis travel of 24" or 32"
- Fast set-up and operation

	TC-40H	TC-80H	TC-120H	TC-160H	TC-240H	TC-320H
X Travel	40"	80"	120"	160"	240"	320"
Y Travel	24" (36")					
Z Travel	24" (32")					
Tool Type/Taper	CAT 40 (CAT 50 Optional) (BT Optional)					
Spindle Speed	60 - 8,500 RPM (10K, 12K, 15K optional)					
ATC Tool Cap	24 Station Arm Type (40 tool optional)					
Rapid Traverse	1,000 X, Y, Z					
Machine Weight	30,000 lbs.	32,000 lbs.	34,000 lbs.	40,000 lbs.	46,000 lbs.	50,000 lbs.

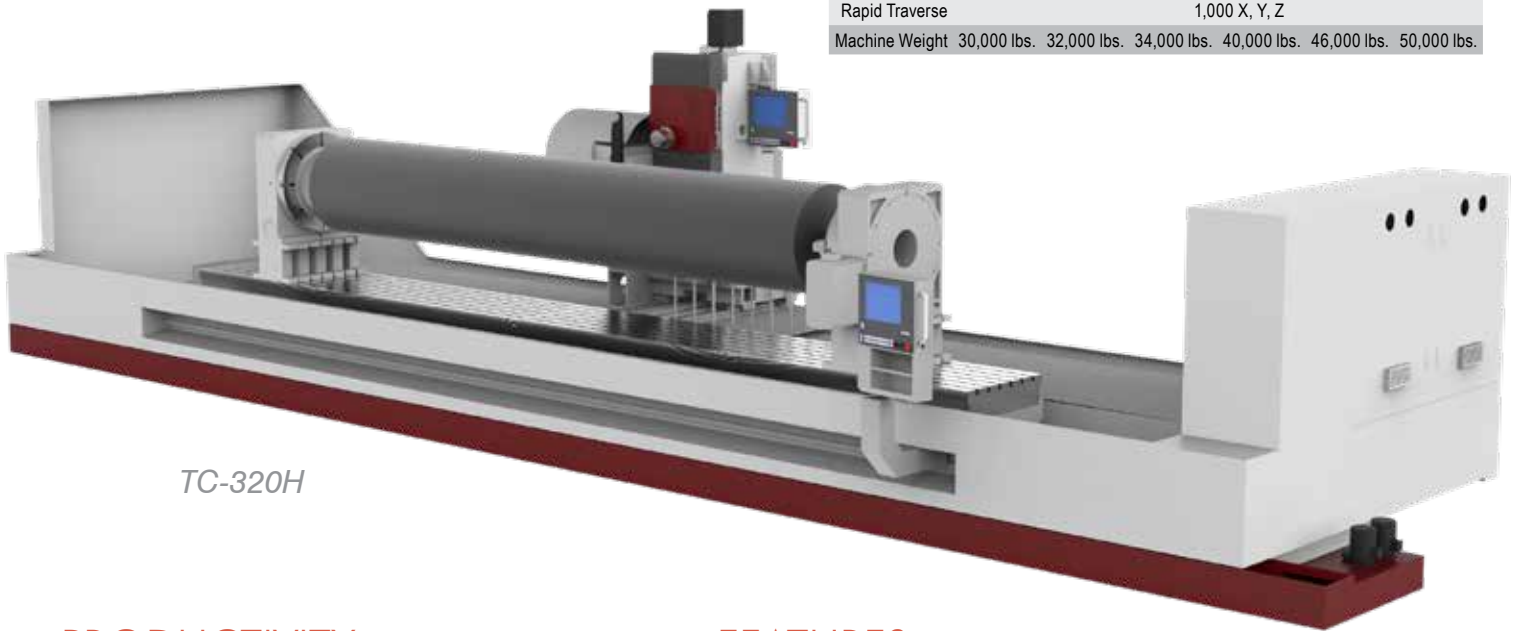

TC-320H

PRODUCTIVITY

- Fixed table with over 10,000 lbs. capacity
- Available built-in rotary table
- Simple menu or G code programming
- Fast set-up keys
- Dual zone with table divider
- Siemens or Fanuc CNC

FEATURES

- Innovative traveling column design
- 40" to 320" X travel
- Z travel of 24" or 32"
- 30 HP 40 or 50 taper spindle
- 1,000 IPM rapid feedrate
- 24 or 40 tool ATC

For more information on the TC-H Series, visit http://www.fryermachine.com/products/horizontal_machining_centers/tch_series.php

TC-V Series - Vertical Traveling Column

Traveling Column Machining Center

- X axis travel to 320"
- Fixed table features high load capacity
- Table divider for work zones
- Y axis travel of 24" or 32"

- TC-40V** 40" x 26" x 28"
- TC-80V** 80" x 24" (32") x 24" (32")
- TC-120V** 120" x 24" (32") x 24" (32")
- TC-160V** 160" x 24" (32") x 24" (32")
- TC-240V** 240" x 24" (32") x 24" (32")
- TC-320V** 320" x 24" (32") x 24" (32")



TC-240V

OVERVIEW

The Fryer TC-V Series features a fixed table and traveling column for flexibility with large parts and fixturing. You can use the machine as a multi-pallet design by using the table dividers to create work zones. The fixed table allows table loads of more than 10,000 lbs. and is available with a built in rotary table. The high torque 40 and 50 taper spindles feature available CTS and gearbox. Available Y axis travel of 24" or 32" and in sizes ranging from 40" X travel all the way to a huge 320" travel machine.

FEATURES

- Traveling column design
- Fixed table with 10,000 lbs. plus capacity
- 24 tool arm type ATC
- 1,000 IPM rapid
- Y travel of 24" or 32"
- Siemens or Fanuc CNC

PRODUCTIVITY

- Standard or tilting head spindle
- Built-in 24" or 32" flush rotary table
- Table mounted 4th axis and tailstock
- Fast conversational programming
- Fast set-up keys
- Open style semi-guarding or fully enclosed

	TC-40V	TC-80V	TC-120V	TC-160V	TC-240V	TC-320V
X Travel	40"	80"	120"	160"	240"	320"
Y Travel	26"			24" (32")		
Z Travel	28"			24" (32")		
Tool Type/Taper	CAT 40 (CAT 50 Optional) (BT Option)					
Spindle Speed	60 - 8,500 RPM (6K, 10K, 12K, 15K Optional)					
ATC Tool Cap	24 Station Arm Type (40 tool optional)					
Rapid Traverse	1,000 X, Y, Z					
Machine Weight	30,000 lbs.	32,000 lbs.	34,000 lbs.	40,000 lbs.	46,000 lbs.	50,000 lbs.

For more information on the TC-V Series, visit http://www.fryermachine.com/products/vertical_machining_centers/tcv_series.php

HR Series - High Performance Horizontal Mills

Fixed Spindle Horizontal Machining Centers

- HR-14** 40" x 20" x 20"
- HR-40** 40" x 29" x 25"
- HR-70** 70" x 55" (72") x 36" (46")
- HR-120** 120" x 55" (72") x 50"
- HR-160** 160" x 55" (72") x 50"

- Rugged fixed spindle design
- Fast set-up and operation
- Excellent small lot machining
- Extra large capacity



HR-40

OVERVIEW

The Fryer HR Series are high performance box way horizontal machining centers designed for your most demanding applications. The high-torque 40 HP spindle motor and 6,000 RPM 50 taper spindle provide rigidity and torque (except HR-14). Extra large castings, ballscrews and bearings provide accuracy and vibration dampening. The user friendly Fryer - Siemens CNC allows shop floor programming for single piece runs or G code programming for high production.

FEATURES

- 24, 40, or 60 tool arm-type ATC
- 50 taper 6,000, 8,000 or 10,000 RPM spindle
- 40 taper 8,000 RPM spindle (HR-14 only)
- High torque 40 HP spindle motor
- Built-in contouring rotary table option
- Semi or full guarding for easy loading
- High pressure coolant thru spindle

PRODUCTIVITY

- Built-in rotary table allows multi-side machining
- Simple menu programming
- Fast set-up keys and manual operation
- Excellent for small lots
- Easy access for large part loading
- Available coolant thru spindle

	HR-14	HR-40	HR-70	HR-120	HR-160
X Travel	40"	40"	70"	120"	160"
Y Travel	20"	29"	55" (72")	55" (72")	55" (72")
Z Travel	20"	25"	36" (46")	50"	50"
Tool Type/Taper	CAT 40 or BT-40		CAT 50 or BT-50		
Spindle Speed	60 - 8,000 RPM		60 - 6,000 RPM (8K, 10K optional)		
ATC Tool Cap	16 Station Arm Type		24 Station Arm Type (30 - 40 - 60 tool optional)		
Rapid Traverse	600 IPM	1,000 IPM	750 IPM	600 IPM	600 IPM
Machine Weight	9,000 lbs.	18,000 lbs.	36,000 lbs.	42,000 lbs.	46,000 lbs.

For more information on the HR Series, visit http://www.fryermachine.com/products/horizontal_machining_centers/hr_series.php



BUILT-IN ROTARY TABLE

Optional feature is a flush mounted 4th axis table, platter available in 24", 36" and 40" diameters. Full interpolated contouring and positioning with 12 arc/sec accuracy. Includes rotary table controller and hydraulic brake.



RECTANGULAR ROTARY TABLE

- Large 60" x 48" table
- 5 Tee slots
- Full interpolated 4th axis
- HR / HB-70 only



HR-70

HB Series - High Performance Boring Mills

Moving Quill Horizontal Boring Mills

HB-70	70" x 55" (72") x 36" (46")
HB-120	120" x 55" (72") x 50"
HB-160	160" x 55" (72") x 50"

- 20" bar type spindle
- High performance cutting
- Fast set-up and operation
- Rugged box way construction



HB-70

OVERVIEW

Fryer's HB Series Boring Mills are heavy duty machines designed for high precision machining. Equipped with a 20" travel bar type spindle and a powerful 40 HP spindle motor. Rugged box way construction and high precision ballscrews ensure high performance cutting and high accuracy tolerances. The user friendly Fryer - Siemens CNC allows shop floor programming for single piece runs or G code programming for high production.

	HB-70	HB-120	HB-160
X Travel	70"	120"	160"
Y Travel	55" (72")	55" (72")	55" (72")
Z Travel	36" (46")	50"	50"
W Travel	20"	20"	20"
Tool Type/Taper	CAT 50 or BT-50		
Spindle Speed	30 - 3,000 RPM		
ATC Tool Cap	24 Station Arm Type (30 - 40 - 60 tool optional)		
Machine Weight	38,000 lbs.	44,000 lbs.	48,000 lbs.

FEATURES

- 50 taper bar type spindle 4.33" diameter
- 20" travel bar fully programmable - W axis
- 3,000 RPM spindle speed
- 40 HP spindle with 360 ft/lbs of torque
- 24, 40, or 60 tool arm-type ATC
- Standard coolant thru spindle

PRODUCTIVITY

- Built-in rotary table allows multi-side machining
- Simple menu programming
- Fast set-up keys and manual operation
- Excellent for small lots
- Easy access for large part loading
- Rugged 4-box way construction

For more information on the HB Series, visit http://www.fryermachine.com/products/horizontal_machining_centers/hb_series.php



BUILT-IN ROTARY TABLE

Optional feature is a flush mounted 4th axis table, platter available in 24", 36" and 40" diameters. Full interpolated contouring and positioning with 12 arc/sec accuracy. Includes rotary table controller and hydraulic brake.



RUGGED BAR-TYPE SPINDLE

- 4.33" Diameter quill
- 20" Programmable travel – W axis
- 50 Taper – 3,000 RPM
- 90 PSI thru spindle coolant



HB-70

VT Series - Vertical Turret Lathe

Compact Large Swing VTL

- VT-60** 60" Swing
- VT-80** 80" Swing
- VT-100** 100" Swing

- Innovative traveling column design
- Large swing in a small foot print machine
- Unique horizontal turret
- Excellent clearance for long & short tools alike

PRODUCTIVITY

- Fast set-up and programming system
- Shop floor programming
- Excellent for small lot production
- Small foot print
- Traveling column provides improved clearance
- Siemens or Fanuc CNC

FEATURES

- Compact design uses half the floor space
- 60", 80" or 100" swing models
- 8 or 12 tool automatic turret
- BMT-65 tooling for high rigidity
- High torque geared headstock
- C axis and live tooling



VT-40

OVERVIEW

The Fryer VT Series is a compact, large swing vertical turret lathe. This series features an innovative traveling column design that allows a large swing in a small foot print machine. The unique horizontal turret features excellent clearance for long and short tools alike. The VT is available with full C axis contouring and positioning as well as a powerful live tool turret. Equipped with Fryer / Siemens 828-HS CNC control that features shop floor conversational programming, G code programming, 3D graphics and fast set-up cycles.



HORIZONTAL TURRET

- Unique horizontal mount
- Added clearance for long tools
- Excellent clearance for short tools
- 8 or 12 tool capacity



LIVE TOOL TURRET

- Powerful 10 HP spindle motor
- Rigid BMT-65 tool holders
- "C" axis spindle features full contouring
- Optional Y axis with +/- 3 inches of travel



VT-60

INNOVATIVE DESIGN

- Traveling column uses much less floor space
- Turret design offers better clearance
- Turning and grinding on one machine
- Automatic loading system
- Excellent ergonomics

UNIQUE TRAVELING COLUMN

- Provides greater rigidity than ram style VTL's
- Column moves away from chuck for part loading
- Super accurate roller type linear ways
- Extremely compact footprint

	VT-60	VT-80	VT-100
Max Swing Diameter	60"	80"	100"
Cutting Diameter Range	0" - 60"	4" - 80"	24" - 100"
Max Cutting Length		32" (48")	
Column Travel (X)	34"	38"	38"
Longitudinal Travel (Z)		32" (48")	
No. of Turret Positions		8 (12)	
Turret Tooling Size		BMT-65	
Spindle Motor HP (Peak)		75 HP	

SL Series - High Precision Slant Lathe

Ultra Accurate Production Turning

- SL-6** 6" Chuck, 1.75" Bar Capacity
- SL-8** 8" Chuck, 2" Bar Capacity
- SL-10** 10" Chuck, 3" Bar Capacity
- SL-12** 12" Chuck, 3.4" Bar Capacity

- Ultra precision spindle cartridge
- C1 class double nut ballscrews
- 45° slant bed and box ways for greater rigidity
- Perfect for shops requiring high rigidity, accuracy & ease of use



SL-12

OVERVIEW

The Fryer SL Series Slant Bed Lathes feature a true 45° slant bed and box ways for greater rigidity. An ultra precision spindle cartridge, C1 class double nut ballscrews and other premium components provide accuracy unmatched by any other lathe in this class. The Fryer / Siemens 828-HS CNC is incredibly easy to use and features fast set-up and conversational programming. The SL series is the perfect choice for shops requiring high rigidity, accuracy and ease of use.

For more information on the SL Series, please visit http://www.fryermachine.com/products/turning_centers/sl_series.php

FEATURES

- 45 degree one piece slant bed
- Ultra precision world class construction
- P4 NN roller spindle bearings
- High precision hydraulic chuck
- Box way construction
- C axis and live tooling

PRODUCTIVITY

- Fast set-up and programming system
- Shop floor and G code programming
- Unmatched accuracy
- Tool and part probe system
- Chip management system
- Siemens or Fanuc CNC



SL-10

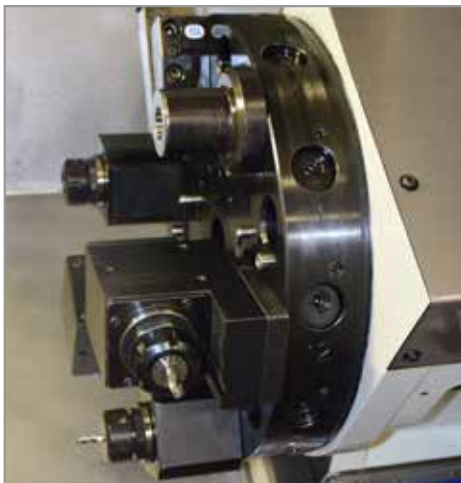

LIVE TOOL TURRET

The optional live tool turret features VDI-style tooling for ease of use in set-up. Fryer's live tool turrets are available in 30 and 40 VDI sizes. The 10 HP live tool spindle motor has low end power and rigid tapping. The CNC provides simple shop floor programming of complicated milling cycles like hex milling, engraving, pocketing and drilling. Fryer also offers Y axis turrets in several different sizes up to 5.1" of travel.

	SL-6	SL-8	SL-10	SL-12
Swing Over Bed	14"	20"	24"	28"
Max Turning Dia	12"	12"	14"	18"
Working Length	9.0"	16" (24", 46")	24" (46", 80")	
Dist. b/ Centers	N/A	19" (27", 51")	27" (51", 83")	
# of Turret Positions	8	12	12	12
Turret Tooling Size	3/4" BOT (VDI-30)	1" BOT (VDI-30, BMT-45)	1" BOT (VDI-40, BMT-55)	
Bar Capacity	1.75"	2.0" (3.0")	3.0" (3.6")	3.6"
Spindle HP (Peak)	20	30	40	40

High Precision Rotary Tables

THE BETTER BUILT ROTARY TABLE

Fryer made rotary tables are better built for longer life and higher accuracy. Gear driven for better power distribution, better accuracy ring and worm gears and better sealing for zero contamination. Backed by a two year warranty, these rotaries are the choice of demanding shops worldwide.



RT-200

- 7.87" diameter faceplate
- 6.30" center height
- 1.37" through hole
- Fast 33 RPM rotate speed

RT-320

- 12.60" diameter faceplate
- 8.27" center height
- 4.33" through hole
- 15 arc/sec accuracy

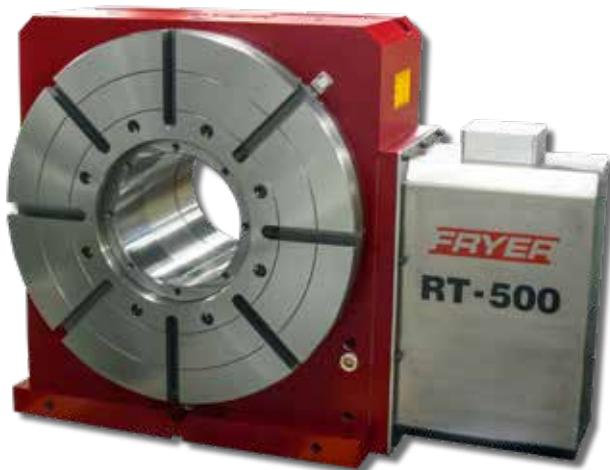

RT-500

- 19.69" diameter faceplate
- 12.2" center height
- 7.09" through hole
- 15 arc/sec accuracy

Also available in 6", 10", 16", 25" and 32"

For more information on Fryer Rotary Tables, please visit http://www.fryermachine.com/products/rotary_tables.php

TILTING ROTARY TABLES

The Fryer TRT series features two axis motion for both 5 axis simultaneous and 4+1 motion. The large platter rotary tables have a small footprint for addition to any VMC or HMC. Gear driven with high accuracy ring and worm gears and exceptional sealing for zero contamination. Available in sizes from 5" all the way to 32" diameter.

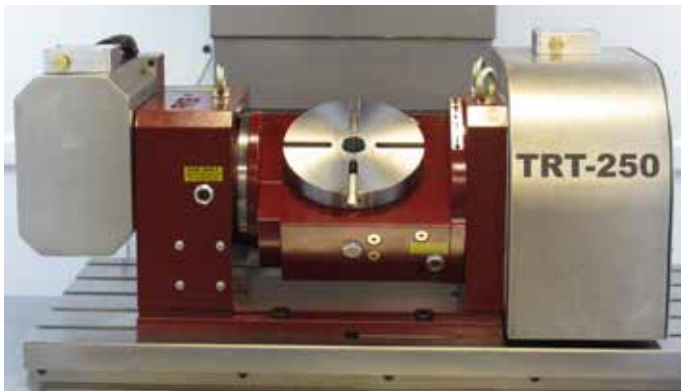

TRT-250

- Large 16.5" part swing
- +/- 120 degree tilt range
- 350 Lbs table load
- Small footprint fits most VMC's

Also available in 5", 8", 12", 18", 20", 24" and 32"

MANUAL TILTING ROTARY TABLES

The Fryer MT series feature a full automatic 4th axis rotary table with manual tilt capability. Designed to lower the cost and size, these table are the perfect choice for small batch production where multiple sided machining is required. Available in sizes from 8" all the way to 25".

MT-250

- 9.84" diameter platter
- Large 20" part swing
- Manual tilt range 0-100 degrees
- 350 Lbs load capacity

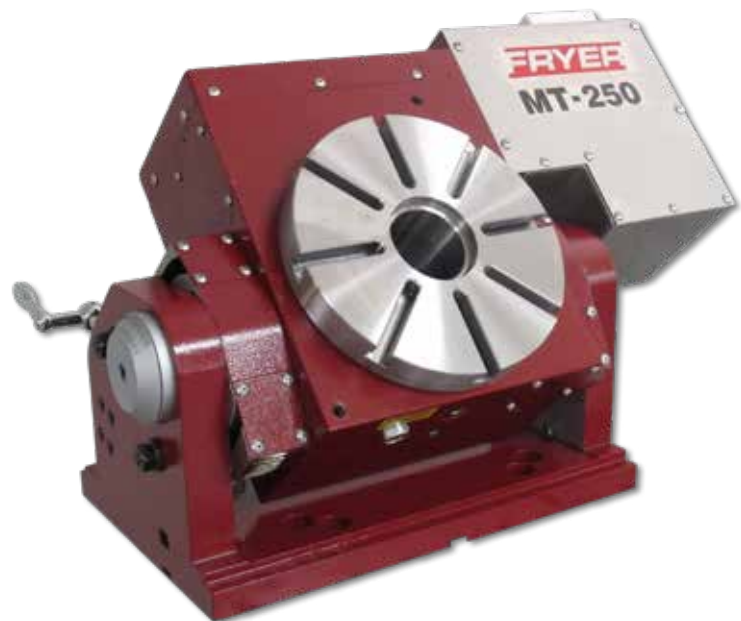

Available in 8", 10", 12", 16", 20" and 25" sizes

Fryer / Siemens 828-HS - CNC Control

OVERVIEW

The Fryer / Siemens 828-HS CNC provides world class technology and ultra-advanced features in an intuitive user interface. Milling in vertical or horizontal and turning all use the same platform with up to 4+1 axis capability. Fast set-up cycles, one button hot keys and built in probe cycles speed the set-up process. Shop floor programming, G code programming, large program storage and Ethernet connectivity speed the programming process. 3D solid model graphic verification, handwheel run and easy interrupt speed the first article process.



EASE OF USE

- One touch keys control many functions
- Shop floor conversational programming
- Manual Mode with Do-One cycles
- Animated cycles with graphics and help
- Handwheel run
- One button tool changes
- Advanced Intuitive tool and part probing cycles
- 3D Shopfloor simulation with cycle time display
- Selectable level lockout key
- USB and Compact Flash Ports

POWERFUL FEATURES

- Mid-program restart
- Multiple Clamping
- High speed machining
- Collision avoidance
- Adaptive feed
- Compatible with tool presetters to import tool data automatically
- In-process measuring
- DXF Import
- Mindsphere

For more information on the 828 Control, please visit http://www.fryermachine.com/products/cnc_control.php

SIMULATION MODE

Before making any chips the full featured simulation mode lets you see the part in 3D to check if everything is correct compared to the print. Part can be rotated, zoomed and cut to see into different areas of the part. Hole in the wrong place? Fix it before you actually machine it. Simulation even shows cycle time.

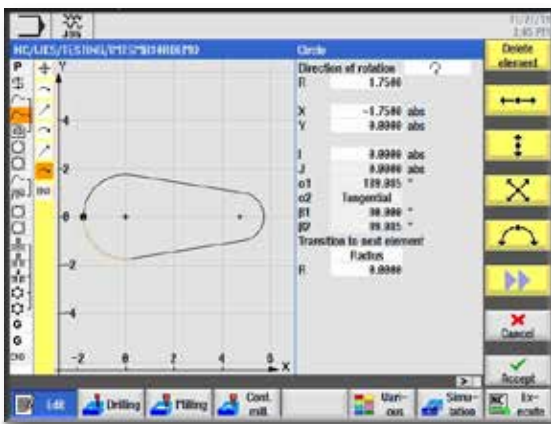
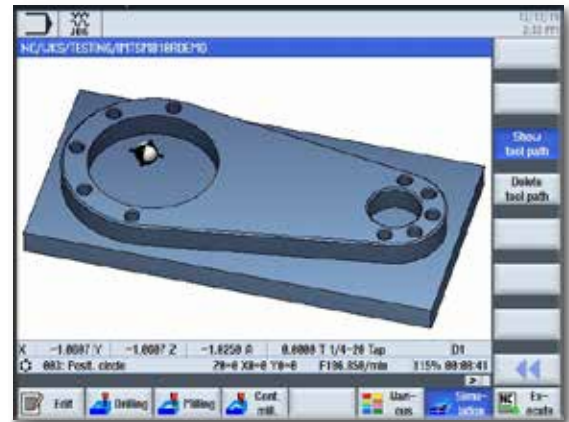

CONTOUR EDITOR

The Contour Editor lets you create simple or complex tool paths. As you enter dimensions the path is visually generated. Don't know an end point? The editor will fill-in missing points.

TOOL TABLE

Graphic display shows the type and name of the tool. You can also control spindle direction and coolant. Tool life monitoring is also standard for time in cut or part count.



HANDWHEEL RUN

This feature allows you to control your program execution with the optional electronic handwheel. Turning the handwheel causes the program to run with you in charge of the axis feed. Turn it slow or speed things up by cranking faster. When you stop turning the axes stop moving, turn the handle the opposite direction and the axes move backwards though the program. Designed to make proving-out programs easier with safety and confidence. (optional)

Fryer / Siemens Touch 2300 - 5-Axis CNC Control

OVERVIEW

The Fryer / Siemens Touch 2300 CNC provides world class technology and ultra-advanced features in an intuitive user interface. Based on the powerful Siemens 840D SL, this state of the art platform provides the ultimate for 5 axis, high speed machining, horizontal machine and turning applications alike. Fast set-up cycles, one button hot keys and built in probe cycles speed the set-up process. Shop floor programming, G code programming, large program storage and Ethernet connectivity speed the programming process. 3D solid model graphic verification, handwheel run and easy interrupt speed the first article process.



MULTI-TOUCH SMART SCREEN

Smart Operation with Multi –Touch interface will give you many of the same familiar functions as other touch screen devices. Scrolling, pinch and zoom and Soft Key selection are intuitive and easy to use.



EASE OF USE

- Smart operation with Multi-Touch 19" screen
- One touch keys control many functions
- Shop floor conversational programming
- Manual Mode with Do-One cycles
- Animated cycles with graphics and help
- Handwheel run
- One button tool changes
- Advanced Intuitive tool and part probing cycles
- 3D Shopfloor simulation with cycle time display
- Selectable level lockout key

POWERFUL FEATURES

- Advanced 5-Axis Operation
- Mid-program restart
- Multiple Clamping
- High speed machining
- Collision avoidance
- Adaptive feed
- 5 axis plus capability
- Mixed Technology – Milling, turning, grinding...
- Compatible with tool presetters to import tool data automatically
- In-process measuring
- DXF Import
- Mindsphere
- Connected shop floor

For more information on the 2300 Control, please visit http://www.fryermachine.com/products/cnc_control.php

Fryer / Fanuc 31i B5 Plus - 5-Axis CNC Control

OVERVIEW

The Fryer / Fanuc 31i B5 Plus is the world's leading 5 axis CNC and provides ultra-advanced features in an industry standard user interface. 5 axis features such as 3D tool nose compensation, tool center point compensation and inverse time feature. Fine surface machining cycle for advance high speed machining. Fast set-up cycles, one button hot keys and industry standard cycles speed the set-up process. Shop floor programming using Fanuc's Manual Guide software, G code programming, large program storage and high speed ethernet connectivity speed the programming process. 3D solid model graphic verification, handwheel run and easy interrupt.



EASE OF USE

- One touch keys control many functions
- Standard G code programming
- Manual mode for easy set up
- Animated graphics
- Handwheel run mode
- One button tool changes
- 3D Shopfloor simulation
- Selectable level lockout key

POWERFUL FEATURES

- Advanced 5-Axis Operation
- Mid-program restart
- Multiple Clamping
- High speed machining
- Collision avoidance
- Adaptive feed
- Mixed Technology – Milling, turning, grinding...
- In-process measuring
- Connected shop floor

FRYER / FANUC 31i B5 PLUS

5-Axis Advanced Machining

- 3D tool nose compensation
- Tool center point compensation
- Inverse time feature
- Fine surface machining cycle

Fryer / Fanuc 0i Plus - CNC Control

OVERVIEW

The Fryer / Fanuc 0i Plus is the world's leading CNC and provides ultra-advanced features in an industry standard user interface. Milling in vertical or horizontal and turning all use the same platform with up to 4+1 axis capability. Fast set-up cycles, one button hot keys and industry standard cycles speed the set-up process. Shop floor programming using Fanuc's Manual Guide software, G code programming, large program storage and high speed ethernet connectivity speed the programming process. 3D solid model graphic verification, handwheel run and easy interrupt speed the first article process.



EASE OF USE

- Shop floor conversational programming
- Manual Mode with 3 handwheels
- Handwheel run
- One button tool changes
- 3D Shopfloor simulation
- Selectable level lockout key

POWERFUL FEATURES

- USB port
- Fine surface machining
- 48 work offsets
- 400 tool offsets
- Tool life management
- 2 MB part program storage
- Compact flash card port

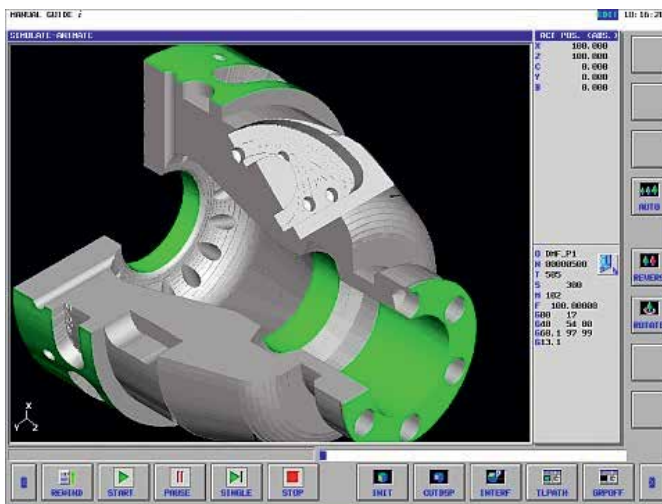

FRYER / FANUC 0i Plus

Toolroom and Production Milling & Turning

- Industry standard G code programming
- Manual Guide conversational programming
- Fast set-up cycles
- High speed machining

For more information on the Fanuc 0i Plus Control, please visit http://www.fryermachine.com/products/cnc_control.php

Specifications



MB-Q SERIES

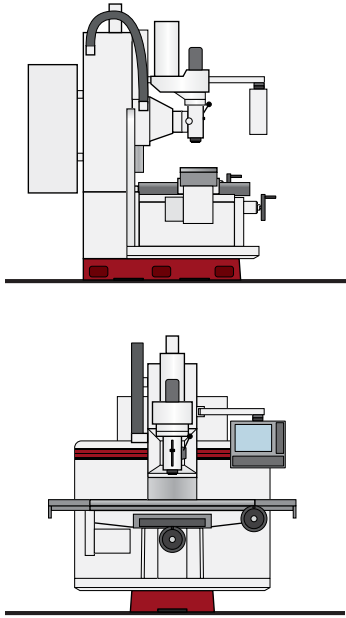

MB-Q SERIES SPECIFICATIONS		MB-10Q	MB-14Q	MB-16Q
MACHINE CAPACITY	X Travel	32"	40"	60"
	Y Travel	17"	20"	25"
	Z Travel	19"	20"	24"
	Table Load (Evenly Distributed)	2,000 lbs.	2,450 lbs.	2,950 lbs.
	Ballscrew Size	1.26"	1.26"	1.57"
	Table Size	14" x 50"	16" x 54"	18" x 70"
SPINDLE	T-Slots (No./Width)	3 / 0.630"	3 / 0.630"	5 / 0.630"
	Table Top to Floor	31"	33"	36"
	Motor (Peak)	10 HP	10 HP	10 HP
	Max Spindle Torque	40 ft/lbs High Gear - 238 ft/lbs Low Gear		
	Spindle Speed (RPM)	Low 10-500 High 100-4,500		
	Speed Ranges	2 Speed Gear Box		
	Tool Type/Taper	CAT 40 (NST 40 or BT 40 Optional)		
	Quill Diameter	4.125"	4.125"	4.330"
	Quill Travel	6"	6"	6"
	Spindle Nose to Table (Max - Min)	23" - 4"	26" - 6"	30" - 6"
PERFORMANCE	Spindle Center to Column	17.5"	20"	25"
	Head Swivel	+/- 90°	+/- 90°	+/- 90°
	Positioning Accuracy	+/- 0.0002"		
	Positioning Repeatability	+/- 0.0001"		
	Rapid Traverse	400 IPM		
GENERAL INFO	Cutting Feed Rate	0.001 - 300 IPM		
	Axis Thrust (Peak)	4,400 lbs.		
	Air Pressure Requirements	85 PSI; 3 CFM		
	Coolant Capacity	12 Gallons		
	Coolant Flow	3 Gal/Min		
	Power Requirements	40 AMP; 208-250 VAC 3 PHASE (380-500 optional)		
	Shipping Dimensions* (WxDxH)	50" x 76" x 76"	54" x 80" x 78"	72" x 92" x 89"
Operating Dimensions (WxDxH)	103" x 80" x 94"	113" x 80" x 106"	174" x 92" x 113"	
Machine Weight	5,000 lbs.	6,000 lbs.	8,800 lbs.	

MB-R SERIES

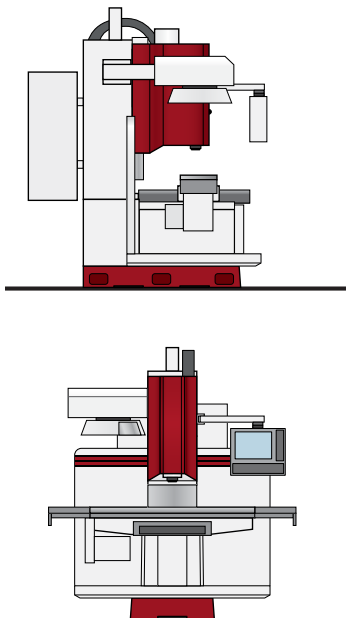

MB-R SERIES SPECIFICATIONS		MB-10R	MB-14R	MB-16R	
MACHINE CAPACITY	X Travel	32"	40"	60"	
	Y Travel	17"	20"	25"	
	Z Travel	19"	20"	24"	
	Table Load (Evenly Distributed)	2,000 lbs.	2,450 lbs.	2,950 lbs.	
	Ballscrew Size	1.26"	1.26"	1.57"	
	Table Size	14" x 50"	16" x 54"	18" x 70"	
SPINDLE	T-Slots (No./Width)	3 / 0.630"	3 / 0.630"	5 / 0.630"	
	Table Top to Floor	31"	33"	36"	
	Motor (Peak)	12 HP	12 HP	12 HP	
	Max Spindle Torque	40 ft/lbs			
	Spindle Speeds (RPM)	60 - 8,000 RPM			
	Tool Type/Taper	CAT 40 (BT-40 Optional)			
	Spindle Nose to Table (Max - Min)	23" - 4"	25" - 5"	28" - 4"	
	Spindle Center to Column	17.5"	20"	25"	
	ATC	Tool Storage Capacity	12 (20 optional)		
		Tool Change Time	7 Seconds		
Tool Selection		Bi-Directional			
Max. Adjacent Tool Diameter		5.5"			
Max. Tool Weight		15.4 LBS			
PERFORMANCE	Max. Tool Length	11.8"			
	Positioning Accuracy	+/- 0.0002"			
	Positioning Repeatability	+/- 0.0001"			
	Rapid Traverse	400 IPM			
	Cutting Feed Rate	0.001 - 300 IPM			
GENERAL INFO	Axis Thrust (Peak)	4,400 lbs.			
	Air Pressure Requirements	85 PSI; 3 CFM			
	Coolant Capacity	12 Gallons			
	Coolant Flow	3 Gal/Min			
	Power Requirements	40 AMP 208-250 VAC 3 Phase (380-500 VAC)			
	Shipping Dimensions* (WxDxH)	50" x 76" x 76"	54" x 80" x 78"	72" x 92" x 89"	
	Operating Dimensions (WxDxH)	103" x 80" x 94"	113" x 80" x 106"	174" x 92" x 113"	
Machine Weight	5,000 lbs.	7,000 lbs.	10,000 lbs.		

CM SERIES

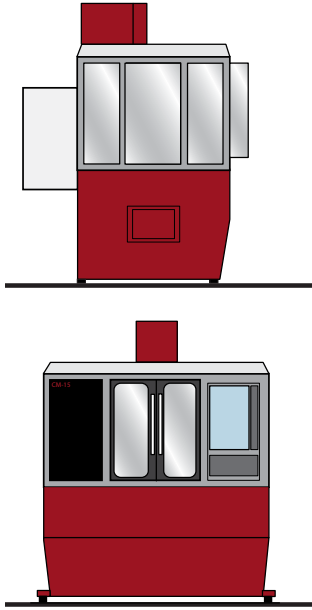

CM SERIES SPECIFICATIONS		CM-15	CM-20
MACHINE CAPACITY	X Travel	15"	20"
	Y Travel	10"	13"
	Z Travel	15"	20"
	Table Load (Evenly Distributed)	350 lbs.	450 lbs.
	Table Size	10" x 32"	12" x 24"
	T-Slots (No./Width)	3 / 0.630"	3 / 0.630"
SPINDLE	Table Top to Floor	32"	30"
	Motor HP (Peak)	7.5 HP	
	Spindle Speed (RPM)	60 - 8,000 RPM (10K, 12K, 15K, 21K, 30K optional)	
	Spindle Torque (max)	35 ft/lbs. @ 350 RPM	
	Tool Type/Taper	CAT 40 (BT option)	
ATC	Spindle Nose to Table (Max - Min)	4" - 19"	3" - 23"
	Tool Storage Capacity	8 Station	10 Station (20 optional)
	Max. Tool Diameter (full)	3.5"	
	Max. Tool Weight	10.4 lbs.	
PERFORMANCE	Max. Tool Length	8"	
	Positioning Accuracy	+/- 0.0002"	
	Positioning Repeatability	+/- 0.0001"	
	Resolution	0.0001"	
	Rapid Traverse	500 IPM (1,200 optional)	
	Cutting Feed Rate	0.001 - 400 IPM (1,200 optional)	
GENERAL INFO	Axis Thrust (Peak)	2,200 lbs. X, Y, Z	
	Air Pressure Requirements	90 PSI - 3 CFM	
	Coolant Capacity	10 Gallons	
	Coolant Flow	2 GPM	
	Door Open Width	23"	30"
	Power Requirements	40 AMP 200-250 VAC 3 PHASE (380-500 optional)	
	Shipping Dimensions* (WxDxH)	55" x 52" x 71"	65" x 80" x 80"
Operating Dimensions (WxDxH)	55" x 52" x 80"	65" x 80" x 80"	
	Machine Weight	2,350 lbs.	4,300 lbs.

ET-TR SERIES

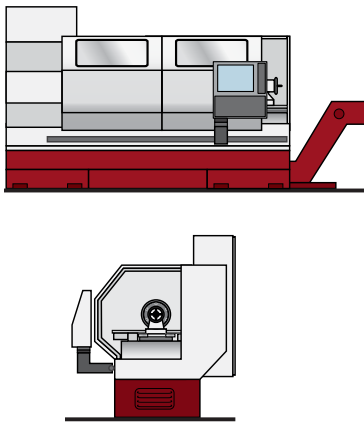

ET-TR SERIES SPECIFICATIONS		ET-16	ET-18	ET-21	ET-25
MACHINE CAPACITY	Swing Over Bed	16"	18"	21"	25"
	Swing Over Cross Slide	8.125"	9.125"	12"	16"
	Swing in Gap	N/A		N/A	
	Distance Between Centers	40" (60")		60" (40", 80", 120")	
	Width of Bed	14"		14"	
	Width of Cross Slide	8.5"		8.5"	
	Cross Slide Travel (X)	10"		12"	12.5"
	Longitudinal Travel (Z)	37"		57"	
	Optional Travel (Z)	57"		37", 77", 117"	
	Max Part Weight - Unsupported	500 lbs		800 lbs	
Max Part Wt. - Supported w/ S/R	1,500 lbs	2,500 lbs	3,000 lbs		
SPINDLE	Spindle Nose	Camlock D1-6	Camlock D1-6 (D1-8)	Camlock D1-8 (A2-11)	
	Spindle Bore	2.05"	2.05" (3.4")	3.40" (4.01")	
	Spindle Nose Taper	MT - 6	MT - 6	Straight	
	Spindle Motor HP (Peak)	10 HP	10 HP	15 HP	
	Spindle Speed (RPM)	100 - 3,000	50 - 2,500	50 - 2,000 (1,500)	
	Speed Ranges	Low 50 - 350		Low 50 - 300	
TAIL-STOCK		High 100 - 3,000	High 350 - 2,500	High 300 - 2,000 (1,500)	
	Speed Selection	Single Gear Range	Auto Shift	Auto Shift	
	Quill Travel	5.0"		5.5"	
PERFORMANCE	Quill Diameter	2.5"			
	Positioning Accuracy	+/- 0.0002"			
	Positioning Repeatability	+/- 0.0001"			
	Rapid Traverse (X,Z)	400 IPM			
GENERAL INFO	Axis Thrust (Peak)	3,058 lbs. X		3,504 lbs. Z	
	Air Requirements	90 PSI - 5 CFM			
	Coolant Capacity	10 Gallons			
	Power Requirements	40 AMP			
	Voltage Requirements	208-250 VAC 3 PHASE (380-500 VAC Optional)			
	Shipping Dimensions* (WxDxH)	86"x72"x68"	86"x72"x68"	106"x76"x68"	106"x76"x68"
	Operating Dimensions (WxDxH)	86"x74"x68"	86"x74"x68"	106"x78"x68"	106"x78"x68"
	Machine Weight	5,000 lbs.	6,500 lbs.	7,500 lbs.	8,500 lbs.

Specifications



ET-LC SERIES

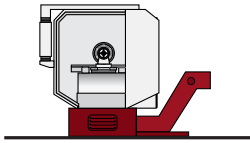
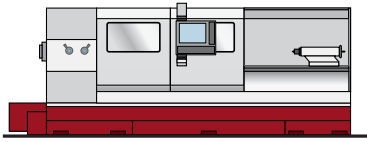

ET-LC SERIES SPECIFICATIONS		ET-30	ET-40
MACHINE CAPACITY	Swing Over Bed	30"	40"
	Swing Over Cross Slide	18"	28"
	Swing in Gap	N/A	N/A
	Distance Between Centers	60"	60"
	Opt. Distance Between Centers	80", 120", 160", 200"	80", 120", 160", 200"
	Width of Bed	19"	19"
	Width of Cross Slide	11"	11"
	Cross Slide Travel (X)	16"	20"
	Longitudinal Travel (Z)	57"	
	Optional Travel (Z)	77", 117", 157", 197"	
Max Part Weight - Unsupported	2,000 lbs		
Max Part Wt. - Supported w/ S/R	10,000 lbs		
SPINDLE	Spindle Nose	Camlock D1-11 (A2-11, A2-15)	
	Spindle Bore	4.10" (6.1", 9.0", 12.0")	
	Spindle Nose Taper	MT - 8	
	Spindle Motor HP (Peak)	30 HP (50 HP)	
	Spindle Speed (RPM)	10 - 1500 (1000, 750)	
	Speed Ranges	Low 1, Low 2, Medium, High	
TAIL-STOCK	Quill Travel	8.0"	
	Quill Diameter	4.1"	
PERFORMANCE	Positioning Accuracy	+/- 0.0002"	
	Positioning Repeatability	+/- 0.0001"	
	Rapid Traverse (X,Z)	400 IPM	
	Axis Thrust (Peak)	4,504 lbs. X 8,700 lbs. Z	
GENERAL INFO	Air Requirements	90 PSI - 5 CFM	
	Coolant Capacity	28 Gallons	
	Voltage Requirements	208-250 VAC 3 PHASE (380-500 VAC Optional)	
	Shipping Dimensions* (WxDxH)	155"(60), 175"(80), 215"(120) x 82 x 78"	
	Operating Dimensions (WxDxH)	155"(60), 175"(80), 215"(120) x 82 x 78"	

ET-XL SERIES

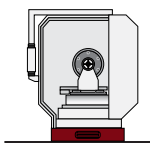
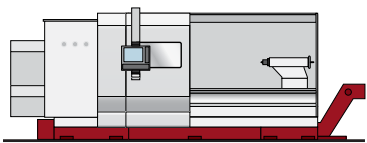

ET-XL SERIES SPECIFICATIONS		ET-50	ET-65	ET-80
MACHINE CAPACITY	Swing Over Bed	50"	65"	80"
	Swing Over Cross Slide	35"	50"	65"
	Distance Between Centers	60"		
	Opt. Distance Between Centers	80", 120", 160", 200", 240", 280", 340"		
	Width of Bed	30"		
	Width of Cross Slide	13.5"		
	Cross Slide Travel (X)	27" (33", 40")		
	Longitudinal Travel (Z)	67"		
	Optional Travel (Z)	87", 126", 165", 205", 244", 284"		
	Max Part Weight - w/ Tailstock	15,000 lbs		
Max Part Wt. - w/ S/R and T/S	20,000 lbs			
SPINDLE	Spindle Nose	A2-11 (A2-15, A2-20, A2-28)		
	Spindle Bore	6.10" (9", 10", 12", 16", 20")		
	Spindle Motor HP (Peak)	50 HP		
	Spindle Speed (RPM)	3 - 750 (600, 375, 300)		
	Spindle Torque (Peak)	19,700 ft/lbs @ 30 RPM		
	Speed Ranges	Low, Medium, High		
TAILSTOCK	Quill Travel	12.0" Hydraulic motor - 9 IPM		
	Quill Diameter	6.50"		
	Quill Spindle Nose	A1-8 - Includes Built in Spindle		
	Tailstock Body Movement	Electric Motor with Rack and Pinion		
PERFORMANCE	Positioning Accuracy	+/- 0.0002"		
	Positioning Repeatability	+/- 0.0001"		
	Resolution	+/-0.00010"		
	Rapid Traverse (X,Z)	400 IPM		
	Axis Thrust (Peak)	8,894 lbs. X 12,720 lbs. Z		
GENERAL INFO	Air Requirements	90 PSI - 5 CFM		
	Coolant Capacity	70 Gallons		
	Voltage Requirements	380-500 VAC		
	Shipping Dimensions* (WxDxH)	145"(60), 205"(120), 245" (160), 285" (200), 325" (240) x 70" x 75"		
	Operating Dimensions (WxDxH)	145"(60), 205"(120), 245" (160), 285" (200), 325" (240) x 70" x 75"		

MC-B SERIES

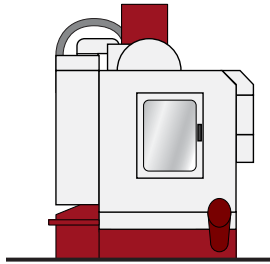
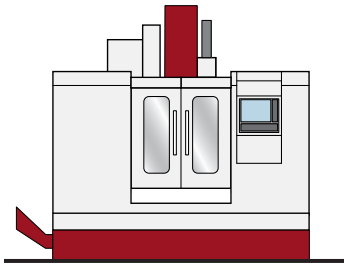

MC-B SERIES SPECIFICATIONS		MC-30B	MC-40B	MC-45B	MC-60B	MC-80B	MC-100B
MACHINE CAPACITY	X Travel	30"	40"	45"	60"	80"	100"
	Y Travel	18"	20"	25"	30" (35")	35" (40")	35" (40")
	Z Travel	22"	28"	25"	28" (38")	30" (34")	30" (34")
	Table Load (Evenly Distributed)	2,500 lbs.	3,000 lbs.	3,500 lbs.	4,500 lbs.	5,500 lbs.	5,500 lbs.
	Table Size	16.5" x 31.5"	20" x 40"	24" x 51"	24" x 67"	30" x 93"	30" x 112"
	T-Slots (No./Width)	3 / .708"	5 / .708"	5 / .708"	5 / .708"	5 / .708"	5 / .708"
SPINDLE	Table Top to Floor	30"	35"	35"	32"	35"	35"
	Motor HP (Peak)	30.0 HP (40.0 HP Optional)					
	Spindle Speed (RPM)	60 - 8,500 RPM (10K, 12K, 15K, 21K, 30K Optional)					
	Spindle Torque (max)	155 ft/lbs @ 350 RPM (204 ft/lbs w/opt 40 HP motor; 800 ft/lbs w/opt 40 HP motor and gearbox)					
	Tool Type/Taper	CAT 40 (CAT 50 Optional) (BT Option)					
	Spindle Nose to Table (Max - Min)	25" - 3"	32" - 4"	29" - 4"	32" - 4"	34" - 4"	34" - 4"
ATC	Spindle Center to Column	18"	21"	26"	30"	36"	36"
	Tool Storage Capacity	24 Station Arm Type (40 Tool)					
	Tool Change Time	3 Seconds					
	Max. Tool Diameter (full)	3.2"					
	Max. Tool Dia. (adjacent empty)	5.9"					
	Max. Tool Weight	15.4 lbs.					
PERFORMANCE	Max. Tool Length	13"					
	Positioning Accuracy X, Y, Z	+/- 0.0002"					
	Positioning Repeatability X, Y, Z	+/- 0.0001"					
	Resolution	0.0001"					
	Rapid Traverse	1,200 X, Y - 900 Z			600 X, Y, Z 400 X, Y, Z		
	Cutting Feed Rate	.001 - 900 IPM			.001 - 400 IPM		
GENERAL INFO	Axis Thrust (Peak)	4,400 lbs. X, Y, Z					
	Air Pressure Requirements	90 PSI - 5 CFM					
	Coolant Capacity	90 Gallons					
	Door Open Width	34"	37"	45"	62"	81"	105"
	Power Requirements	40 AMP 380-500 VAC 3 PHASE (208-250 VAC Optional)					
	Shipping Dimensions* (WxDxH)	93"x86"x76"	99"x86"x88"	127"x87"x87"	161"x89"x93"	210"x94"x95"	240"x94"x96"
Operating Dimensions (WxDxH)	93"x86"x89"	111"x86"x110"	127"x104"x110"	161"x112"x112"	211"x122"x114"	240"x122"x114"	

MC-L SERIES

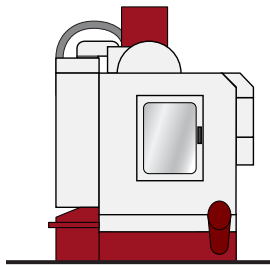
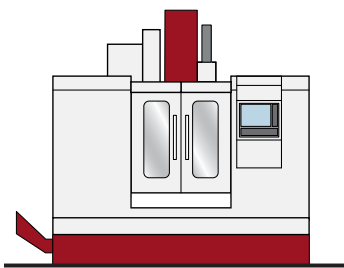

MC-L SERIES SPECIFICATIONS		MC-24L	MC-30L	MC-40L	MC-45L	MC-60L
MACHINE CAPACITY	X Travel	24"	30"	40"	45"	60"
	Y Travel	16"	20"	22"	25"	30" (35")
	Z Travel	17"	20"	22"	25"	28" (38")
	Table Load (Evenly Distributed)	2,000 lbs.	2,500 lbs.	3,000 lbs.	3,500 lbs.	4,500 lbs.
	Table Size	16.5" x 27.5"	20" x 35"	22" x 43"	24" x 51"	24" x 67"
	T-Slots (No./Width)	3 / .708"	5 / .708"	5 / .708"	5 / .708"	5 / .708"
SPINDLE	Table Top to Floor	28"	30"	32"	32"	32"
	Motor HP (Peak)	20.0 HP	20.0 HP	20.0 HP	30.0 HP	30.0 HP
	Spindle Speed (RPM)	60 - 10,000 RPM (12K, 15K, 21K, 30K Optional)				
	Spindle Torque (max)	100 ft/lbs @ 350 RPM			155 ft/lbs @ 350 RPM	
	Tool Type/Taper	Big Plus CAT 40 (BT Option)				
	Spindle Nose to Table (Max - Min)	24" - 4"	24" - 4"	26" - 4"	29" - 4"	32" (42") - 4"
ATC	Spindle Center to Column	18"	21"	23"	26"	31"
	Tool Storage Capacity	30 Station High Speed Arm Type (40 Option)				
	Tool Change Time	1.5 Seconds				
	Max. Tool Diameter (full)	3.2"				
	Max. Tool Dia. (adjacent empty)	5.9"				
	Max. Tool Weight	15.4 lbs.				
PERFORMANCE	Max. Tool Length	13"				
	Positioning Accuracy X, Y, Z	+/- 0.0002"				
	Positioning Repeatability X, Y, Z	+/- 0.0001"				
	Resolution	0.0001"				
	Rapid Traverse	1,450 X, Y, Z	1,450 X, Y, Z	1,450 X, Y, Z	1200 X, Y, Z	1200 X, Y, Z
	Cutting Feed Rate	.001 - 1,200 IPM				
GENERAL INFO	Axis Thrust (Peak)	4,000 lbs. X, Y, Z				
	Air Pressure Requirements	90 PSI - 5 CFM				
	Coolant Capacity	90 Gallons				
	Door Open Width	28"	32"	42"	47"	62"
	Power Requirements	40 AMP 380-500 VAC 3 PHASE (208-250 VAC Optional)				
	Shipping Dimensions* (WxDxH)	83"x76"x72"	93"x86"x76"	100"x97"x88"	127"x87"x87"	161"x89"x93"
Operating Dimensions (WxDxH)	83"x76"x85"	93"x86"x89"	120"x97"x114"	127"x104"x110"	161"x112"x112"	

Specifications



VB SERIES

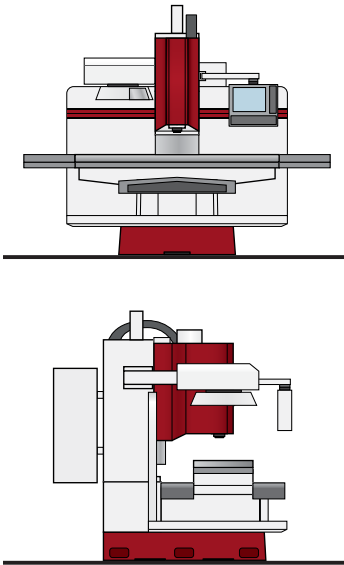

VB SERIES SPECIFICATIONS		VB-60	VB-80	VB-100	VB-120	VB-160
MACHINE CAPACITY	X Travel	60"	80"	100"	120"	160"
	Y Travel	30"	35" (40")	35" (40")	40" (50")	40" (50")
	Z Travel	28"	26" (34")	26" (34")	40"	40"
	Table Load (Evenly Distributed)	4,000 lbs.	5,000 lbs.	5,000 lbs.	6,500 lbs.	6,500 lbs.
	Table Size	24" x 73"	30" x 93"	30" x 112"	40" x 126"	40" x 165"
	T-Slots (No./Width)	5 / .709"	5 / .709"	5 / .709"	5 / .709"	5 / .709"
	Table Top to Floor	32"	35"	35"	35"	35"
SPINDLE	Motor HP (Peak)	30.0 HP (40.0 HP Optional)				
	Spindle Speed (RPM)	60 - 8,000 RPM (10K, 12K, 15K Refrigerated Optional)				
	Spindle Torque (max)	155 ft/lbs @ 350 RPM (204 ft/lbs w/ 40 HP motor; 800 ft/lbs w/ 40 HP motor & gearbox)				
	Speed Ranges	1 Range (2-Speed Gear Box Optional)				
	Tool Type/Taper	CAT 40 or BT-40 (Optional 50 Taper)				
	Spindle Nose to Table (Max - Min)	31" - 3"	30" - 4"	30" - 4"	44" - 4"	44" - 4"
	Spindle Center to Column	30.5"	36" (41")	36" (41")	42" (51")	42" (51")
ATC	Tool Storage Capacity	20 Carousel (24, 40, 60 Arm Type Optional)				
	Max. Tool Diameter (full)	4.10" (3.2")				
	Max. Tool Dia. (adjacent empty)	7.9" (5.9")				
	Max. Tool Weight	16.5 lbs. (15.4)				
PERFORMANCE	Max. Tool Length	15" (13")				
	Positioning Accuracy	+/- 0.0003"				
	Positioning Repeatability	+/- 0.0002"				
	Rapid Traverse (IPM)	1,000 X, Y - 700 Z	600	400	400	400
GENERAL INFO	Cutting Feed Rate (IPM)	.001 - 600 IPM	.001 - 600 IPM	.001 - 400 IPM	.001 - 400 IPM	.001 - 400 IPM
	Axis Thrust (Peak)	3,500 lbs.	4,400 lbs.	4,400 lbs.	10,800 lbs.	10,800 lbs.
	Air Pressure Requirements	90 PSI 5 CFM				
	Coolant Capacity	20 Gallons (90 Gallons)				
	Power Requirements	40 AMP 380-500 VAC 3 PHASE (208-250 VAC Optional)				
	Shipping Dimensions* (WxDxH)	83" x 92" x 92"	100" x 94" x 96"	120" x 94" x 96"	140" x 105" x 105"	180" x 105" x 105"
	Operating Dimensions (WxDxH)	170" x 100" x 110"	220" x 110" x 110"	240" x 110" x 110"	260" x 120" x 120"	300" x 120" x 120"

5X SERIES

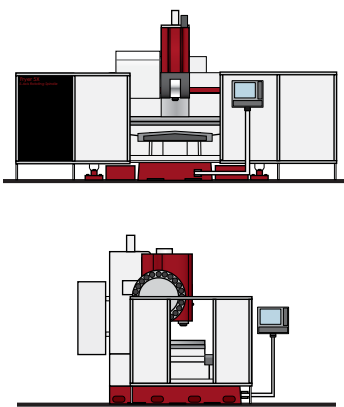

5X SERIES SPECIFICATIONS		5X-60	5X-100	5X-120	5X-160
MACHINE CAPACITY	X Travel	60"	100"	120"	160"
	Y Travel	30"	35"	50"	50"
	Z Travel	35"	34"	40"	40"
	A Travel	+/- 95°	+/- 95°	+/- 105°	+/- 105°
	C Travel	+/- 200°	+/- 200°	+/- 200°	+/- 200°
	Table Load (Evenly Distributed)	5,000 lbs.	5,000 lbs.	7,500 lbs.	8,500 lbs.
	Table Size	24" x 67"	30" x 112"	40" x 126"	40" x 165"
	Way Type	Linear	Linear	Box Ways	Box Ways
	T-Slots (No./Width)	5 / 0.709"	5 / 0.709"	5 / 0.709"	5 / 0.709"
	Table Top to Floor	32"	35"		38"
SPINDLE	Motor HP (Peak)	35.0 HP		55.0 HP	
	Spindle Speed (RPM)	200 - 18,000 RPM		200 - 15,000 RPM	
	Spindle Torque (max)	40 ft/lbs. @ 1,000 RPM		90 ft/lbs. @ 2,000 RPM	
	Tool Type/Taper	HSK-63A			
	Spindle Nose to Cntr. of Rotation	11"			
	Spindle Nose to Table - Vertical	0 - 30"		0 - 32.5"	
	Spindle Nose to Table - Horizontal	5" - 40"	5" - 39"	4" - 43"	4" - 43"
	Spindle Center to Column	30"	36"	51"	51"
ATC	Tool Storage Capacity	40-Station Arm Type (60 Tool optional)			
	Tool Change Time	3 Seconds			
	Max. Tool Diameter (full)	3.0"			
	Max. Tool Dia. (adjacent empty)	5.9"			
PERFORMANCE	Max. Tool Weight	15.0 lbs.			
	Max. Tool Length	13"			
	Positioning Accuracy X, Y, Z	+/- 0.0002"			
	Positioning Repeatability X, Y, Z	+/- 0.0001"			
	Positioning Accuracy A, C	5 Seconds			
	Position Repeatability A, C	3 Seconds			
	Rapid Traverse	1,200 IPM X, Y, Z	800 IPM X, Y, Z	400 IPM X, Y, Z	
	Cutting Feed Rate	0.001 - 800 IPM X, Y, Z 100 IPM A, C			
GENERAL INFO	Power Requirements	150 AMP 380-500 VAC 3 PHASE			
	Shipping Dimensions* (WxDxH)	161" x 89" x 93"	120" x 94" x 96"	140" x 105" x 105"	180" x 105" x 105"
	Operating Dimensions (WxDxH)	161" x 112" x 112"	240" x 110" x 110"	285" x 135" x 126"	300" x 135" x 126"

TR SERIES

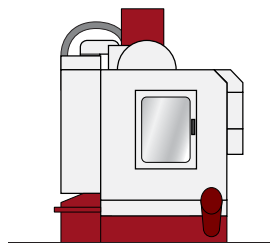
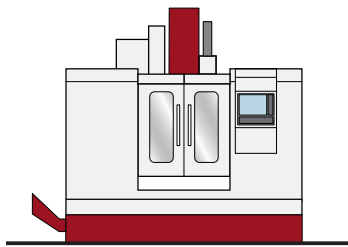

TR SERIES SPECIFICATIONS		TR-200	TR-320	TR-600
MACHINE CAPACITY	X Travel	14"	20"	30"
	Y Travel	14"	16"	24"
	Z Travel	20"	22"	25"
	C Travel	360°	360°	360°
	A Travel	0 - 110°	0 - 120°	0 - 120°
	Table Load (Evenly Distributed)	4,000 lbs.	6,000 lbs.	8,000 lbs.
	Platter Size	8" ø	12" ø	24" ø
	Maximum Workpiece Diameter	10.5"	23.62"	32.67"
	Maximum Workpiece Height	9"	12"	15"
	Table Top to Floor	28"	30"	28"
SPINDLE	Motor HP (Peak)	20 HP	30 HP	30 HP
	Spindle Speed (RPM)	60 - 12,000 RPM (15K, 21K, 30K Opt)		
	Spindle Torque	95 ft/lbs. @ 350 RPM		
	Tool Type/Taper	BIG PLUS CAT-40 (BT-40)		
	Spindle Nose to Table (Max - Min)	22" - 4"	26" - 4"	29" - 4"
Spindle Center to Column	14"	18"	26"	
ATC	Tool Storage Capacity	24-Station High Speed Arm Type (40 tool)		
	Max. Tool Diameter (full)	3.2"		
	Max. Tool Dia. (adjacent empty)	5.9"		
PERFORMANCE	Positioning Accuracy X, Y, Z	+/- 0.0002"		
	Positioning Repeatability X, Y, Z	+/- 0.0001"		
	Tilting Accuracy (A Axis)	30 Arc/Sec		
	Rotary Accuracy (C Axis)	15 Arc/Sec		
	Rapid Traverse	1,200 X,Y, Z		
GENERAL INFO	Cutting Feed Rate	0.001 - 1,200 IPM		
	Coolant Capacity	90 Gallons		
	Door Open Width	28"	35"	48"
	Power Requirements	40 AMP 380-500 VAC 3 Phase (220 VAC optional)		
	Shipping Dimensions* (WxDxH)	83"x76"x72"	93"x86"x76"	127"x87"x87"
	Operating Dimensions (WxDxH)	83"x76"x85"	93"x86"x89"	127"x104"x110"

SX SERIES

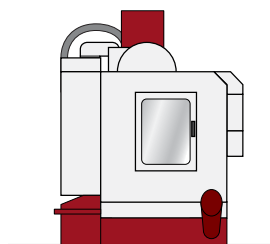
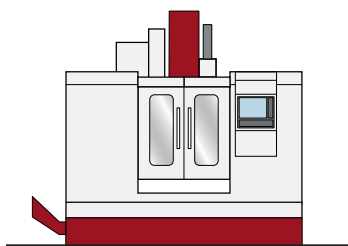

SX SERIES SPECIFICATIONS		SX-45	SX-60	SX-80
MACHINE CAPACITY	X Travel	45"	60"	80"
	Y Travel	25"	30"	35"
	Z Travel	25"	35"	34"
	B Travel	+/- 110°	+/- 110°	+/- 110°
	C Travel	+/- 360°	+/- 360°	+/- 360°
	Table Load (Evenly Distributed)	5,500 lbs.	7,500 lbs.	10,000 lbs.
	Machine Table Size	24" x 51"	24" x 67"	30" x 93"
	Built-in Rotary Table Size	24"	24"	30"
	Way Type	Roller Type Linear		
	T-Slots (No./Width)	5 / 0.709"		
SPINDLE	Table Top to Floor	35"		
	Motor HP (Peak)	40.0 HP		
	Spindle Speed (RPM)	100 - 18,000 RPM		
	Spindle Torque (max)	85 ft/lbs. @ 850 RPM		
	Tool Type/Taper	BIG PLUS CAT-40 (BT-40, HSK-63)		
ATC	Spindle Nose to Cntr. of Rotation	11"		
	Spindle Nose to Table	29" - 4"	37" - 2"	36" - 2"
	Spindle Center to Column	26"	31"	36"
	Tool Storage Capacity	40-Station Arm Type		
PERFORMANCE	Tool Change Time	3 Seconds		
	Max. Tool Diameter (full)	3.2"		
	Max. Tool Dia. (adjacent empty)	5.9"		
	Positioning Accuracy X, Y, Z	+/- 0.0002"		
	Positioning Repeatability X, Y, Z	+/- 0.0001"		
	Positioning Accuracy B, C	15 Seconds (5 Seconds)		
	Position Repeatability B, C	5 Seconds (2 Seconds)		
GENERAL INFO	Axis Rapid Traverse	1,200 IPM X, Y 1,000 IPM Z		
	Cutting Feed Rate	0.001 - 900 IPM		
	Coolant Capacity	100 Gallons		
	Power Requirements	80 AMP 430-500 VAC 3 PHASE (220 VAC optional)		
Shipping Dimensions* (WxDxH)	127" x 87" x 87"	161" x 89" x 93"	110" x 94" x 95"	
Operating Dimensions (WxDxH)	127" x 104" x 110"	161" x 112" x 112"	211" x 122" x 114"	

Specifications



TC-H SERIES

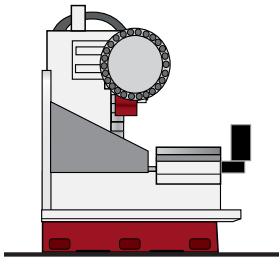
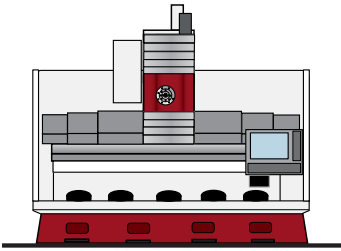

TC-H SERIES SPECIFICATIONS		TC-40H	TC-80H	TC-120H	TC-160H	TC-240H	TC-320H
MACHINE CAPACITY	X Travel	40"	80"	120"	160"	240"	320"
	Y Travel			24" (36")			
	Z Travel			24" (32")			
	Table Load (Evenly Distributed)	8,000 lbs.	8,000 lbs.	10,000 lbs.	10,000 lbs.	14,000 lbs.	18,000 lbs.
	Table Size	60" x 24"	80" x 24"	120" x 24"	160" X 24"	240" X 24"	320" x 24"
	T-Slots (No./Width)	5 / .787"					
SPINDLE	Table Top to Floor	38"					
	Motor HP (Peak)	30.0 HP					
	Spindle Speed (RPM)	60 - 8,500 RPM (10K, 12K, 15K Optional)					
	Spindle Torque (max)	155 ft/lbs (800 ft/lbs w/opt gearbox)					
	Tool Type/Taper	CAT 40 (CAT 50 Optional) (BT Optional)					
	Spindle Nose to Table (Max - Min)	28" - 4" (40" - 4")					
ATC	Spindle Nose to Table Center	10" - 28" (10" - 26")					
	Tool Storage Capacity	24 Station Arm Type (40 tool optional)					
	Tool Change Time	3.0 seconds (4 sec 50 taper)					
	Tool Change Time Chip to Chip	4.0 seconds (6 sec 50 taper)					
	Max. Tool Diameter (full)	3.20" (5.90" 50 taper)					
	Max. Tool Dia. (adjacent empty)	6.25" (9.50" 50 taper)					
PERFORMANCE	Max. Tool Weight	15.4 lbs (30 lbs 50 taper)					
	Max. Tool Length	13" (16" 50 taper)					
	Positioning Accuracy	+/- 0.0002"	+/- 0.0002"	+/- 0.0002"	+/- 0.0003"	+/- 0.0003"	+/- 0.0003"
	Positioning Repeatability	+/- 0.0001"	+/- 0.0001"	+/- 0.0001"	+/- 0.00015"	+/- 0.00015"	+/- 0.00015"
	X Axis Drive Type	Ballscrew	Ballscrew	Ballscrew	Rack & Pinion	Rack & Pinion	Rack & Pinion
	Rapid Traverse	1,000 X,Y, Z					
GENERAL INFO	Cutting Feed Rate	.001 - 600 IPM					
	Axis Thrust (Peak)	4,955 lbs. X, Y, Z					
	Air Pressure Requirements	90 PSI - 5 CFM					
	Coolant Capacity	100 Gallons					
	Power Requirements	40 AMP 400 - 500 VAC 3 PHASE (80 amp)					
	Operating Dimensions (WxDxH)	160"x138"x118"	200"x138"x118"	245"x138"x118"	310"x138"x118"	375"x138"x118"	440"x138"x118"
Machine Weight	30,000 lbs.	32,000 lbs.	34,000 lbs.	40,000 lbs.	46,000 lbs.	50,000 lbs.	

TC-V SERIES

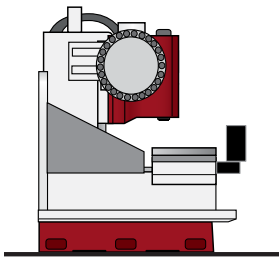
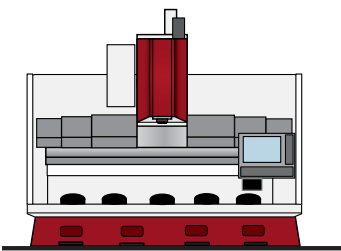

TC-V SERIES SPECIFICATIONS		TC-40V	TC-80V	TC-120V	TC-160V	TC-240V	TC-320V
MACHINE CAPACITY	X Travel	40"	80"	120"	160"	240"	320"
	Y Travel	26"			24" (32")		
	Z Travel	28"			24" (32")		
	Table Load (Evenly Distributed)	8,000 lbs.	8,000 lbs.	10,000 lbs.	10,000 lbs.	14,000 lbs.	18,000 lbs.
	Table Size	60" x 24"	80" x 24"	120" x 24"	160" X 24"	240" X 24"	320" x 24"
	T-Slots (No./Width)	5 / .787"					
SPINDLE	Table Top to Floor	38"					
	Motor HP (Peak)	30.0 HP (40.0 HP Optional)					
	Spindle Speed (RPM)	60 - 8,500 RPM (6K, 10K, 12K, 15K Optional)					
	Spindle Torque (max)	155 ft/lbs @ 350 RPM (204 ft/lbs w/opt 40 HP motor; 800 ft/lbs w/opt 40 HP motor and gearbox)					
	Tool Type/Taper	CAT 40 (CAT 50 Optional) (BT Option)					
	Spindle Nose to Table (Max - Min)	30" - 2"					
ATC	Spindle Center to Column	28"					
	Tool Storage Capacity	24 Station Arm Type (40 tool optional)					
	Tool Change Time	3.0 seconds (4 sec 50 taper)					
	Tool Change Time Chip to Chip	4.0 seconds (6 sec 50 taper)					
	Max. Tool Diameter (full)	3.20" (5.90" 50 taper)					
	Max. Tool Dia. (adjacent empty)	6.25" (9.50" 50 taper)					
PERFORMANCE	Max. Tool Weight	15.4 lbs. (30 lbs 50 taper)					
	Max. Tool Length	13" (16" 50 taper)					
	Positioning Accuracy	+/- 0.0002"	+/- 0.0002"	+/- 0.0002"	+/- 0.0002"	+/- 0.0003"	+/- 0.0003"
	Positioning Repeatability	+/- 0.0001"	+/- 0.0001"	+/- 0.0001"	+/- 0.0001"	+/- 0.00015"	+/- 0.00015"
	X Axis Drive Type	Ballscrew	Ballscrew	Ballscrew	Ballscrew	Rack & Pinion	Rack & Pinion
	Rapid Traverse	1,000 X,Y, Z					
GENERAL INFO	Cutting Feed Rate	.001 - 600 IPM					
	Axis Thrust (Peak)	4,955 lbs. X, Y, Z					
	Air Pressure Requirements	90 PSI - 5 CFM					
	Coolant Capacity	100 Gallons					
	Power Requirements	40 AMP 400 - 500 VAC 3 PHASE (80 amp)					
	Operating Dimensions (WxDxH)	160"x138"x118"	200"x138"x118"	245"x138"x118"	310"x138"x118"	375"x138"x118"	440"x138"x118"
Machine Weight	30,000 lbs.	32,000 lbs.	34,000 lbs.	40,000 lbs.	46,000 lbs.	50,000 lbs.	

HR SERIES

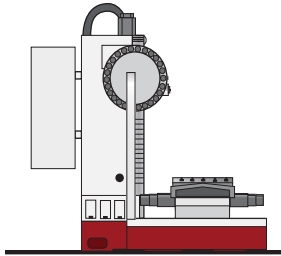
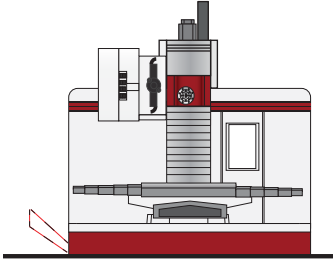

HR SERIES SPECIFICATIONS		HR-14	HR-40	HR-70	HR-120	HR-160
MACHINE CAPACITY	X Travel	40"	40"	70"	120"	160"
	Y Travel	20"	29"	55" (72")	55" (72")	55" (72")
	Z Travel	20"	25"	36" (46")	50"	50"
	Table Load (Evenly Distributed)	3,500 lbs.	6,000 lbs.	10,000 lbs.	10,000 lbs.	10,000 lbs.
	Table Size	16" x 54"	24" x 51"	36" x 80"	40" x 126"	40" x 165"
	T-Slots (No./Width)	5 / 0.63"	5 / 0.709"	5 / 0.866"	7 / 0.709"	7 / 0.709"
SPINDLE	Table Top to Floor	33.8"	35"	40"	38"	38"
	Motor HP (Peak)	20 HP	40.0 HP (55 HP)			
	Spindle Speed (RPM)	60 - 8,000 RPM		60 - 6,000 RPM (8,000 and 10,000 RPM)		
	Spindle Torque	80 ft/lbs 350 RPM		306 ft/lbs. @ 350 RPM (1,224 ft/lbs. with 2-speed gearbox)		
	Speed Ranges	1 range (2-speed ZF gearbox optional)				
	Tool Type / Taper	CAT 40 or BT-40		CAT 50 or BT-50		
BUILT-IN ROTARY OPTION	Spindle Nose to Table Center	29" - 9"	2" - 27"	7" - 43"	10" - 60"	10" - 60"
	Spindle Center to Table Top	22" - 2"	7.5" - 36.5"	5" - 60"	10" - 65"	10" - 65"
	Platter Size	16"	24"	36"	40"	40"
	Max. Rotation Speed	33 RPM	12 RPM			
	Max. Table Load	3,000 lbs.	6,000 lbs.	10,000 lbs.	10,000 lbs.	10,000 lbs.
	Positioning Accuracy	12 arc seconds				
ATC	Positioning Repeatability	5 arc seconds				
	Spindle Center to Table Top	16" - 0	1" - 30"	0" - 53"	2" - 57"	2" - 57"
	Tool Storage Capacity	16 Station Arm Type		24 Station Arm Type (30-40-60 tool)		
	Max. Tool Diameter (full)	5.90"				
	Max. Tool Dia. (adjacent empty)	9.85"				
	Positioning Accuracy	+/- 0.0002"				
PERFORMANCE	Positioning Repeatability	+/- 0.0001"				
	Rapid Traverse	600 IPM X, Y, Z	1,000 IPM X, Y, Z	750 IPM X, Y, Z	600 IPM X, Y, Z	600 IPM X, Y, Z
	Cutting Feed Rate	.001 - 400 IPM				
		0.001 to 600 IPM				
INFO	Shipping Dimensions* (WxDxH)	54" x 80" x 78"	73" x 92" x 92"	120" x 94" x 96"	140" x 105" x 105"	180" x 105" x 105"
	Operating Dimensions (WxDxH)	113" x 80" x 106"	150" x 100" x 100"	180" x 150" x 145"	260" x 150" x 145"	300" x 150" x 145"

HB SERIES

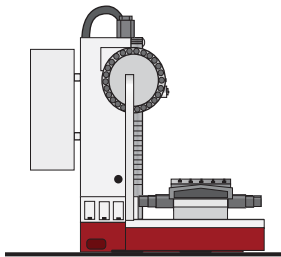
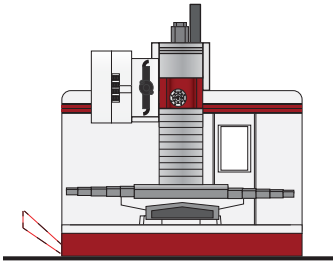

HB SERIES SPECIFICATIONS		HB-70	HB-120	HB-160
MACHINE CAPACITY	X Travel	70"	120"	160"
	Y Travel	55" (72")	55" (72")	55" (72")
	Z Travel	36" (46")	50"	50"
	W Travel	20"	20"	20"
	Table Size	36" x 80"	40" x 126"	40" x 165"
	Table Load (Evenly Distributed)	10,000 lbs.	10,000 lbs.	10,000 lbs.
SPINDLE	T-Slots (No./Width)	5 / 0.866"	7 / 0.709"	7 / 0.709"
	Table Top to Floor	40"	38"	38"
	Bar Diameter (Quill Size)	4.330"		
	Bar Travel (W Axis)	20.0" Fully Programmable "W" axis		
	Spindle Motor HP (Peak)	40.0 HP (55 HP)		
	Spindle Speed (RPM)	30 - 3,000 RPM		
BUILT-IN ROTARY OPTION	Spindle Torque (Max)	360 ft/lbs. @ 350 RPM (1,400 ft/lbs with 2-speed gearbox)		
	Speed Ranges	1 Range (2-speed ZF gearbox optional)		
	Tool Type/Taper	CAT 50 or BT-50		
	Spindle Nose to Table Center	2" - 27"	7" - 43"	16" - 66"
	Spindle Center to Table Top	5" - 60"	5" - 60"	5" - 60"
	Platter Size	36"	40"	40"
ATC OPTION	Maximum Rotation Speed	12 RPM		
	Maximum Table Load	10,000 lbs.		
	Positioning Accuracy	12 arc seconds		
	Position Repeatability	5 arc seconds		
	Spindle Center to Table Top	0" - 53"		
	Tool Storage Capacity	24 Station Arm Type (30-40-60 tool)		
PERFORMANCE	Max. Tool Diameter (full)	5.90"		
	Max. Tool Dia. (adjacent empty)	9.85"		
	Positioning Accuracy	+/- 0.0002"		
	Positioning Repeatability	+/- 0.0001"		
INFO	Rapid Traverse	750 IPM X, Y, Z	600 IPM X, Y, Z	600 IPM X, Y, Z
	Cutting Feed Rate	0.001 - 600 IPM		
INFO	Shipping Dimensions* (WxDxH)	120" x 94" x 96"	140" x 105" x 105"	180" x 105" x 105"
	Operating Dimensions (WxDxH)	195" x 185" x 145"	260" x 185" x 145"	300" x 185" x 145"

Specifications



VT SERIES

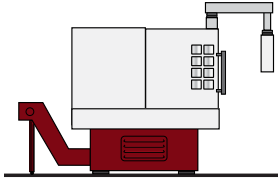
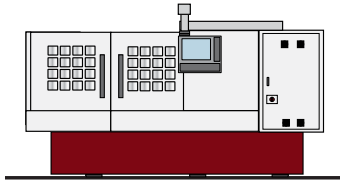

VT SERIES SPECIFICATIONS		VT-60	VT-80	VT-100
MACHINE CAPACITY	Maximum Swing Diameter	60"	80"	100"
	Cutting Diameter Range	0" - 60"	4" - 80"	24" - 100"
	Maximum Cutting Length	32" (48")	32" (48")	32" (48")
	Width of Bed	32"	32"	32"
	Column Travel (X)	34"	38"	38"
	Turret Face to Spindle Center (X)	-4" - 30"	12" - 40"	22" - 50"
	Longitudinal Travel (Z)		32" (48")	
	Turret Face (bottom) to Spindle Nose max/min (Z)		8" - 40" (8" - 56")	
	Number of Turret Positions		8 (12)	
	Live Tooling Spindle (Opt)		10 HP 10 - 4,000 RPM	
Turret Tooling Size		BMT-65		
Ballscrew Size		2.00" X, Z		
Maximum Part Weight		10,000 lbs.		
SPINDLE	Spindle Nose		A2-15	
	Spindle Nose Taper		N/A	
	Spindle Bore		2.625	
	Spindle Motor HP (Peak)		75 HP	
	Max Spindle Torque (peak)		2,700 ft/lbs	
PERFORMANCE	Spindle Speed (RPM)	10 - 500	10 - 500	10 - 300
	Positioning Accuracy		+/- 0.0002"	
	Positioning Repeatability		+/- 0.0001"	
	Rapid Traverse (X, Z)		1,000 IPM	
	Servo Type		AC Digital Brushless	
GENERAL INFO	Axis Thrust (Peak)		6,504 lbs. X, Z	
	Air Requirements		90 PSI - 5 CFM	
	Coolant Capacity		75 Gallons	
	Coolant Flow		8 GPM	
	Power Requirements		125 AMP	
GENERAL INFO	Voltage Requirements		380-500 VAC 3 PHASE	
	Shipping Dimensions* (WxDxH)	155" x 76" x 115"	175" x 90" x 115"	195" x 110" x 115"
	Operating Dimensions (WxDxH)	155" x 76" x 125"	175" x 90" x 125"	195" x 110" x 125"
	Machine Weight	32,000 lbs.	37,000 lbs.	43,000 lbs.

SL SERIES

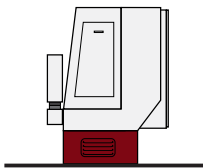
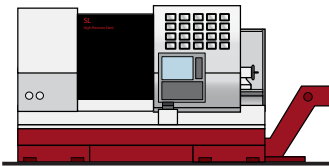

SL SERIES SPECIFICATIONS		SL-6	SL-8	SL-10	SL-12
MACHINE CAPACITY	Swing Over Bed	14"	20"	24"	28"
	Max Turning Diameter	12"	12"	14"	18"
	Working Length	9.0"	16" (24", 46")		24" (46", 80")
	Distance Between Centers	N/A	19" (27", 51")		27" (51", 83")
	Cross Slide Travel (X)	7.5"	7.5"	8.5"	11"
	Longitudinal Travel (Z)	9.5"	16" (24", 48")		24" (46", 80")
	Number of Turret Positions	8	12		12
SPINDLE	Turret Tooling Size	3/4" BOT (VDI-30)	1" BOT (VDI-30, BMT-45)	1" BOT (VDI-40, BMT-55)	
	Turret Index Time (one tool)	1 sec	1 sec	1 sec	
	Spindle Nose	A2-5	A2-6	A2-8	
	Spindle Bore	2.2"	2.4"	3.4"	4.17"
	Bar Capacity	1.75"	2.0" (3.0")	3.0" (3.6")	3.6"
TAILSTOCK	Hydraulic Chuck Size	6"	8" (10")	10" (12")	12" (15")
	Spindle Speed Max (RPM)	6,000	4,200	3,500	3,000
	Spindle HP (Peak)	20	30	40	40
	Quill Travel	N/A	4.0"	4.0"	4.0"
	Quill Diameter	N/A	3.15"	3.15"	4.15"
PERFORMANCE	Quill Taper Hole	N/A	MT-4	MT-4	MT-5
	Positioning Accuracy		+/-0.00010"		
	Positioning Repeatability		+/-0.00005"		
	Rapid Traverse (X,Z)		1,200 IPM		
	Servo Type		AC Digital Brushless		
GENERAL INFO	Axis Thrust (Peak)	3,360 lbs. X, Z	6,360 lbs. X, Z	6,360 lbs. X, Z	10,732 lbs. X, Z
	Coolant Capacity		40 Gallons		
	Coolant Flow		5 GPM		
	Power Requirements	40 AMP	40 AMP	80 AMP	80 AMP
	Voltage Requirements		380-500 VAC 3 PHASE (208-250 VAC Optional)		
GENERAL INFO	Shipping Dimensions* (WxDxH)	70"x50"x60"	90"x69"x70"	108"x69"x70"	128"x69"x70"
	Operating Dimensions (WxDxH)	70"x50"x60"	90"x69"x70"	108"x69"x70"	128"x69"x70"
	Machine Weight	5,500 lbs.	11,500 lbs.	14,500 lbs.	16,000 lbs.

FRYER

MACHINE SYSTEMS

Precision Built Solutions



DESIGNED, ENGINEERED
& ASSEMBLED IN USA

Phone: 845-878-2500
Fax: 845-878-2525
Email: info@fryermachine.com
sales@fryermachine.com
Website: www.fryermachine.com

© 2022 Fryer Machine Systems, Inc.
70 Jon Barrett Road
Patterson, New York 12563 USA